



**general
rubber**

From the Simple to the Simply Amazing

PERFORMANCE RUBBER EXPANSION JOINTS

SPRAY SHIELDS • PENETRATION SEALS

PINCH VALVES • DUCK BILL CHECK VALVES

From the Simple to the Simply Amazing

General Rubber is proud to have been at the forefront of innovative rubber expansion joint and other mechanical rubber product design since 1950. Our commitment to using advanced materials and technologies has differentiated us as a clear leader in the industry. With our ISO 9001 and 14001 certified, state-of-the-art, US-based manufacturing facility, we leverage our capabilities to lower operating costs while remaining environmentally responsible. Together, with our world-class engineers and technical sales team, we provide powerful solutions to even the most demanding applications across multiple industries and sectors. We are particularly proud of our EPC focused **Best Piping Practice and Optimization (BPPO) program** and our MRO focused **Plant Reliability and Efficiency Program (PREP)**. We are confident we can be of service to you and thank you for your consideration.



BPPO

- System Optimization with Reduced Footprint and Energy Consumption
- Minimize Loads on Piping, Equipment and Support Structure
- Reduce Material and Construction Costs
- Direct Engineering Support with Full Comprehension of Piping Codes and Standards for Seamless Integration
- Performance Rubber Expansion Joints with Advanced Restrained and Unrestrained Designs

PREP

- Transition to a Condition-Based Predictive Maintenance Program
- FMEA Approach with Improved Assessment of Failure Modes
- Industry Best Practices, Direct Training and Technical Support
- Plant Surveys Performed with Traditional and Advanced Inspection Methods
- Performance Replacement Rubber Expansion Joints



Additional Services & Capabilities

- OEM Solutions
- Technical Support
- Engineering Services
- Strategic Alliances
- Training
- Field Services
- Testing Capabilities
- Compliance & Certifications

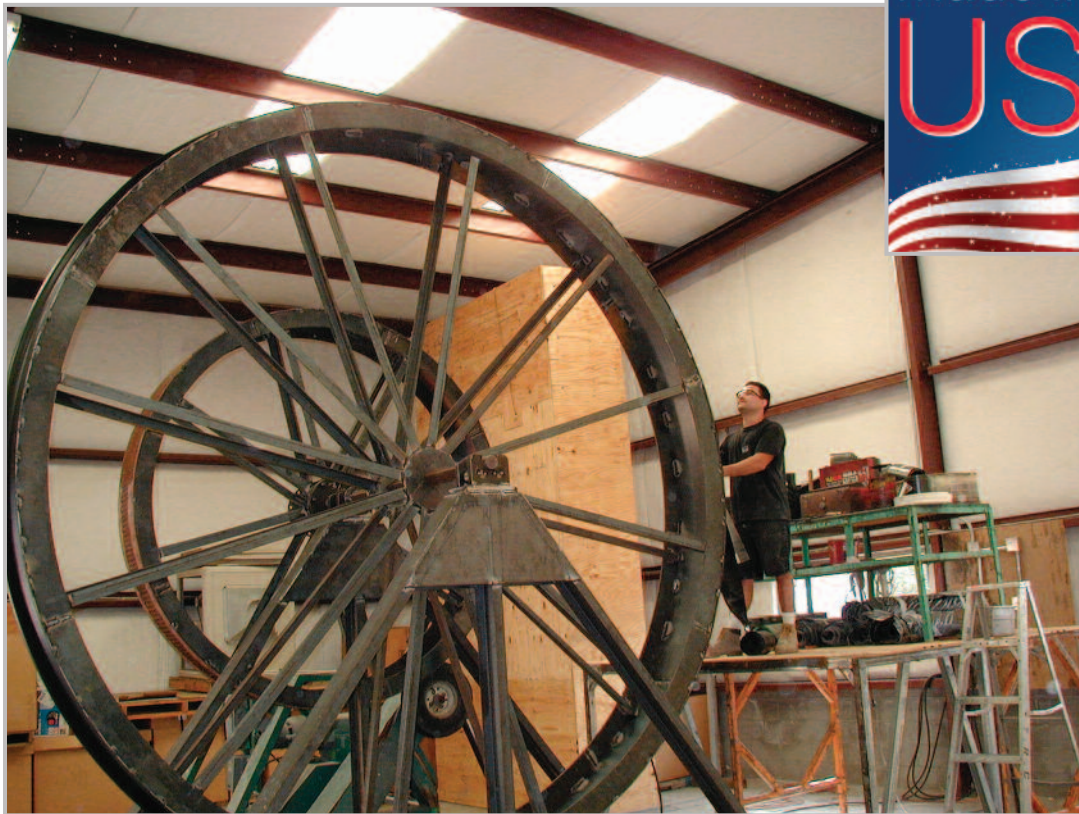

Manufacturing Capabilities

We can manufacture standard and custom expansion joints in a wide range of sizes, materials and arrangements, our specialty being large diameter and offset arrangements. With our modern, US-based facility we can also accommodate several large-scale projects simultaneously. (Photo of 144" ID style 1101 shown above.)

Performance Rubber Expansion Joints

General Rubber's performance rubber expansion joints are designed to

- Absorb Large All-Directional Movements
- Reduce Noise and Vibration
- Have a Cycle Life in the Tens of Millions
- Compensate for Misalignments
- Provide Access to Piping and Equipment
- Relieve Pipe and Anchor Stresses
- Have Superior Chemical and Abrasion Resistance

Materials of Construction

Elastomers: EPDM, Neoprene, Chlorobutyl, Buna-N, Hypalon Alternatives, HNBR, Pure Gum Rubber, PTFE Fluoroplastic, Viton/FKM, FDA/NSF Service

Reinforcements: Polyester, Nylon and Kevlar/Aramid High Tensile Tire Cord, Fiberglass, High Tensile Steel.

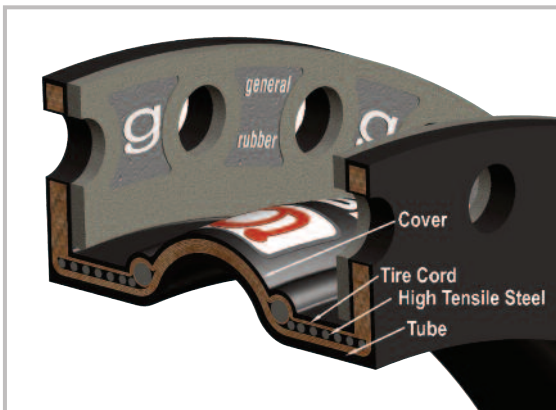

Construction

The spool type body is constructed with full rubber flanges, a high-grade leak-proof tube, multiple layers of high-strength tire cord, high tensile steel reinforcement, a seamless cover, and hot dip galvanized steel retaining rings.

The Unrestrained Expansion Joint (single unrestrained joint illustrated below) represents the most cost-effective arrangement when used in rigid piping systems with main anchors (MA) and numerous guides at specific spacing. Control units can be used as limit rods for secondary restraint, or as tie rods when the support structure or adjacent equipment has load limitations.



Maxi-Joint®



Style 1101 Single (1) Wide Arch Rubber Expansion Joint with large all-directional movements and low stiffness (spring rates). 36" ID X 10" FF shown.



Style 1102 Double (2) Wide Arch Rubber Expansion Joint with twice the movement and half the spring rate of style 1101. 36" ID X 15" FF shown.



Style 1103 Triple (3) Wide Arch Rubber Expansion Joint with triple the movement and one-third the spring rate of style 1101. 36" ID X 20" FF shown.



Style 1104 Quadruple (4) Wide Arch Rubber Expansion Joint with quadruple the movement and one-quarter the spring rate of style 1101. 36" ID X 24" FF shown.

Style 1015 Single (1) Wide Arch Rubber Expansion Joint is General Rubber's most cost-effective full pressure design. *



Style 8101 Single (1) Arch Slip-On Sleeve Type Rubber Expansion Joints are designed with lower spring rates for reduced reaction forces and greater movement capabilities within a compact body. This optimally designed slip-on and lightweight construction represents the most cost-effective arrangement for low pressure applications. Mating flanges and hardware are not required, adding to the cost-effectiveness of this arrangement. *12" ID X 8" OAL shown above.*

Style 8102 Double (2) Arch Slip-On Sleeve Type Rubber Expansion Joints have twice the all-directional movement capabilities with half the spring rates of our single arch design. *

Style 8103 Triple (3) Arch Slip-On Sleeve Type Rubber Expansion Joints have triple the all-directional movement capabilities with one-third the spring rates of our single arch design. *



Styles 1101CR and 1101ER Concentric and Eccentric Reducing Rubber Expansion Joints are an economical way of combining a reducing pipe fitting with an expansion joint. Additionally, the two different flanged diameters can be manufactured with concentric or eccentric centerlines. *18" ID X 12" ID X 14" FF, Style 1101CR shown above.*

Control Units can be designed as limit rods (gap) or tie rods (no gap) depending on the application. They are designed for the internal pressure thrust forces of the system and can be attached to the external or internal hardware of the expansion joint. The arrangement may include a combination of rubber grommets and flat or spherical washers, as well as internal limits for specific applications. * *Style SW/SW control unit with outer & inner spherical washers shown.*

Performance Rubber Expansion Joints

Style 1101LW Lightweight Rubber Expansion Joints are designed with lower spring rates for reduced reaction forces and greater movement capabilities within a compact body. *

Style 1101HP High Pressure Rubber Expansion Joints are designed for higher pressure applications. The standard spool type body is reinforced with additional layers of high-strength tire cord and high tensile steel reinforcements. *

Style 1101HT High Temperature Rubber Expansion Joints are designed for higher temperature applications. The spool type body is constructed with a high temperature resistant EPDM or Viton® leak-proof tube and seamless cover with Kevlar® high temperature and high-strength tire cord reinforcement. *

** Visit us online for these product images.*



Styles 1101LO and 1101AO Lateral and Angular Offset Rubber Expansion Joints are designed with built-in lateral or angular offsets to accommodate non-standard field conditions. They provide ease of installation without compromising any performance capabilities. 36" ID, Style 1101LO shown left.

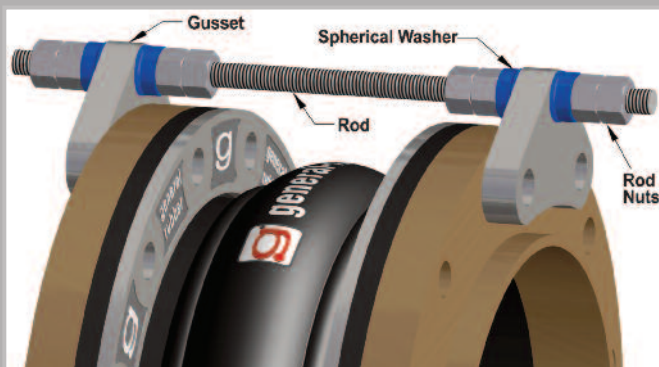
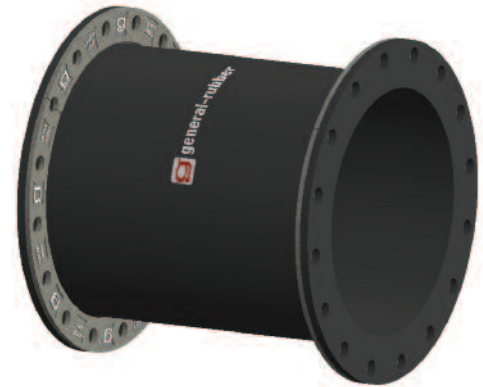

Style 1100 Rubber Flanged Pipe is an economical way of combining a straight length of pipe with an expansion joint. 18" ID X 24" FF, Style 1100 shown above.

Styles 1100EF, 1100TF and 1100YF Rubber Flanged Fittings are an economical way of combining an elbow, tee, or wye pipe fitting with an expansion joint. *

Restrained Rubber Expansion Joints

The selection and application of General Rubber's advanced restrained expansion joints can be used to provide piping system flexibility while restraining pressure thrust forces and other external loads. This approach allows for an optimal design with a smaller footprint. Some of the economic benefits of using advanced restrained expansion joints include fewer guides, anchors and supports.

Style 5100H Hinge Rubber Expansion Joints are designed to facilitate and isolate angular rotation in one plane. The arrangement consists of a pair of hinge plates connected with pins and attached to the external or internal hardware of the expansion joint. The hinge assembly must be designed for the internal pressure thrust forces of the system. *18" ID X 10" FF with externally mounted hinge assembly shown below right.*

This hinge arrangement can be used in sets of two or three to absorb large lateral movements in a single plane. This optimally designed arrangement is an effective solution for absorbing large axial thermal movements from an adjacent pipe run (shown below with two hinge joints).

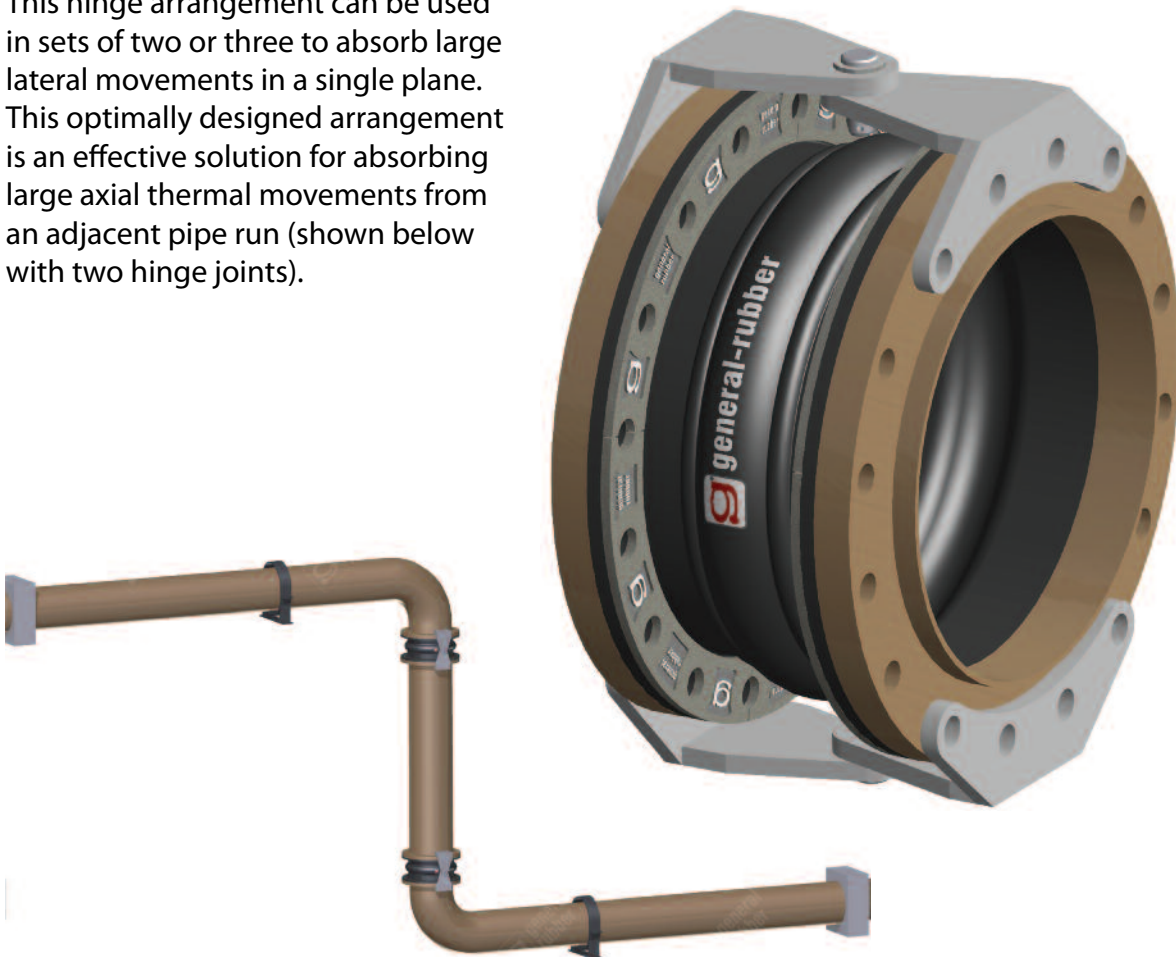

Style 5100U Universal Rubber Expansion Joints feature two resilient arch sections separated by a straight section to facilitate greater lateral movement capability. The tied restraints are attached to the external or internal hardware of the expansion joint. *18" ID X 36" FF with externally mounted tie rods shown at left.*

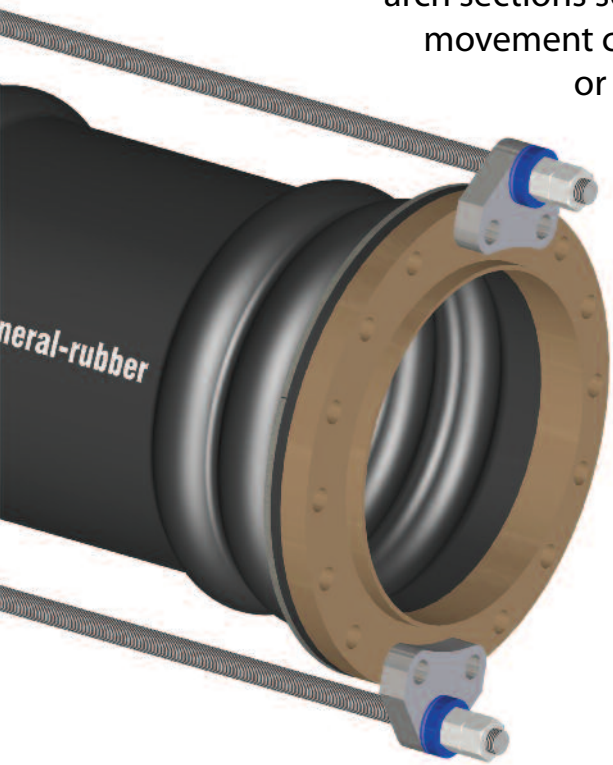

The single unit arrangement shown below represents an effective solution for absorbing axial thermal movements from adjacent pipe runs.



Visit general-rubber.com for our animated demos!

Style 5100G Gimbal Rubber Expansion Joints are designed to facilitate and isolate angular rotation in two planes. The arrangement consists of two pairs of hinge plates connected with pins to a common gimbal ring and attached to the external or internal hardware of the expansion joint. The gimbal assembly must be designed for the internal pressure thrust forces of the system. *18" ID X 10" FF with internally mounted gimbal assembly shown below.*

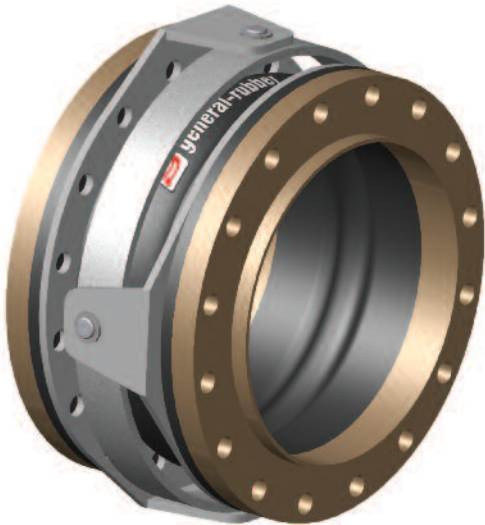

This gimbal arrangement can be used in sets of two, or sets of two with a single hinge design to absorb large lateral movements in multiple planes. This optimally designed arrangement represents an effective solution for absorbing large axial thermal movements from adjacent pipe runs (shown above with two gimbal joints).



Advanced Restrained Rubber Expansion Joints

The selection and application of advanced restrained rubber expansion joint designs can be used for custom solutions to specific and demanding applications.

Style 5100P In-Line Pressure Balanced Rubber Expansion Joint is the only effective solution for directly absorbing large axial thermal movements while continuously self-restraining the pressure thrust force. This arrangement consists of tie devices inter-connecting its main joint sections to its opposing balancing joint sections. The balancing joint section needs to have twice the effective thrust area as the main joint sections in order to balance the arrangement and provide somewhat of an internal anchor location. *36" ID X 36" FF shown right.*



As illustrated here, these expansion joints are commonly used when the support structure or adjacent equipment has load limitations.

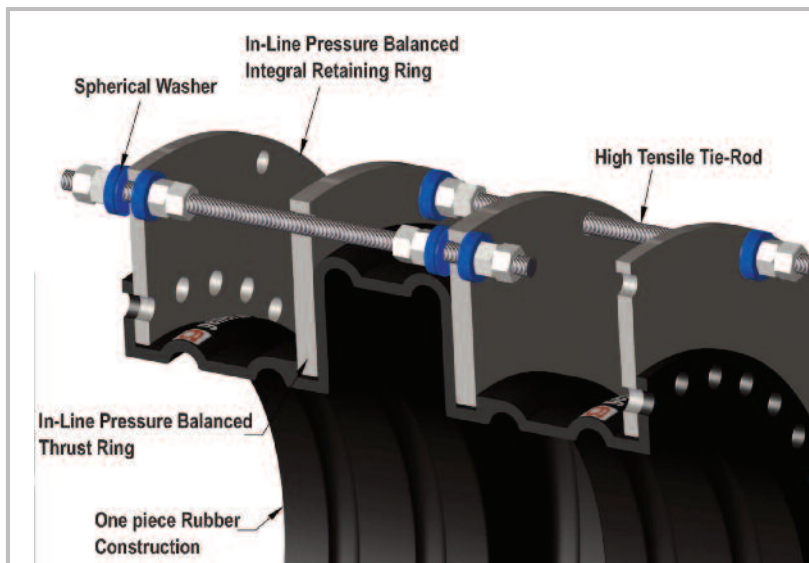

Construction

The body is a one-piece rubber construction with full rubber flanges, a high-grade leak-proof tube, multiple layers of high-strength tire cord, high tensile steel reinforcement, a seamless cover and hot dip galvanized steel retaining rings.

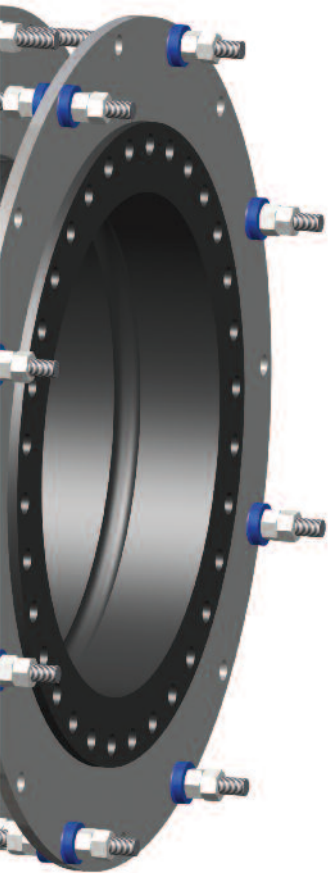

Style 5100E Elbow Pressure Balanced Rubber Expansion Joints are designed to absorb all-directional movement while continuously self-restraining the pressure thrust forces. This arrangement consists of tie devices inter-connecting its main joint section to its opposing balancing joint section and functioning in an elbow configuration. The balancing joint section needs only to have the same effective thrust area as the main joint sections because the center tee fitting provides for an effective internal anchor location. *18" ID shown right.* These are commonly used when the support structure or adjacent equipment has load limitations (see illustration at right).

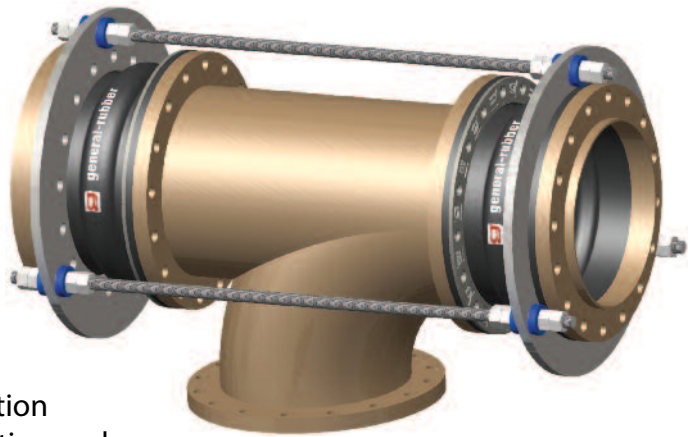

Visit general-rubber.com for our animated demos.



Dismantling Rubber Expansion Joints are designed for self-retraction to facilitate access to piping and equipment, as well as for unmatched ease of installation and subsequent removal due to its pre-compression capabilities. *36" ID X 14" FF shown at left.*

Pre-compression illustration shown below left, and self-retraction illustration shown below right.

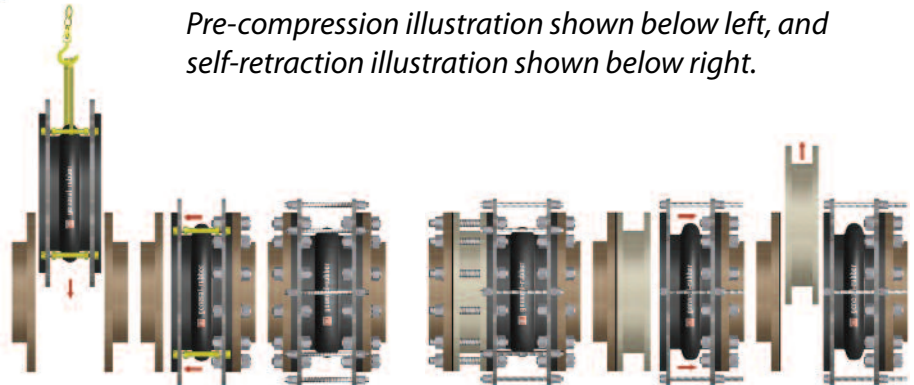

Ducting Expansion Joints



Styles 8100LW, 8101LW and 1091 Rubber Slip-On Sleeves are designed with lower spring rates for reduced reaction forces and greater movement capabilities within a compact body. This optimally designed slip-on and lightweight construction represents the most cost-effective arrangement for low pressure applications. Mating flanges and hardware are not required, adding to the cost-effectiveness of this arrangement.

Visit general-rubber.com for more ducting styles.



Style 9101 Rubber Flanged Versatile ducting rubber expansion joint is designed with an integral arch in a hand wrapped construction. This results in lower spring rates for reduced reaction forces and greater movement capabilities within a compact body. This optimally designed lightweight construction represents the most versatile arrangement for even the most demanding ducting applications. Available in multiple arch, round, and rectangular styles, as well as with built-in offsets.



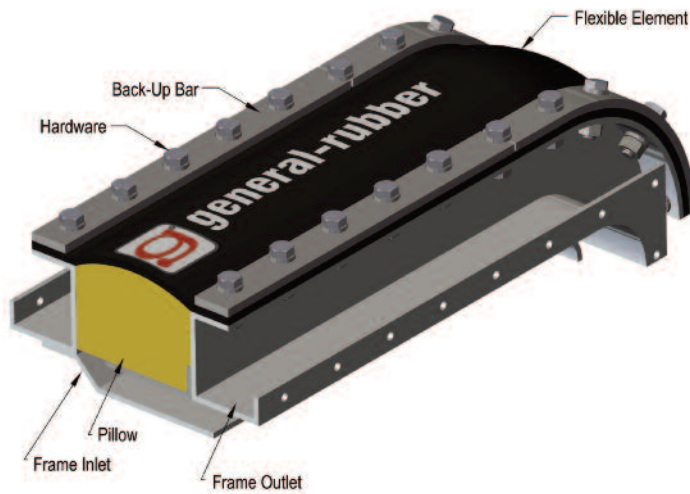

Style 1096 PTFE Composite ducting expansion joints are designed for flue gas continuous service up to 1200°F. This construction is optimally designed with PTFE fluoropolymer composite flexible elements, cavity pillows, steel frames, and flow liners as the support structures and applications require. Composite layering includes a heat- and abrasion-resistant high tensile fiberglass reinforcement (gas side), insulation matting, 9 mm thick PTFE corrosion barrier (dew point sensitive), insulation matting, high tensile fiberglass reinforcement, and an outer layer of PTFE fluoropolymer coated high tensile fiberglass.

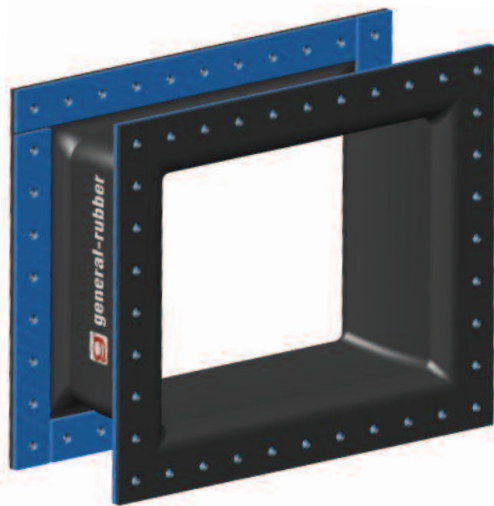
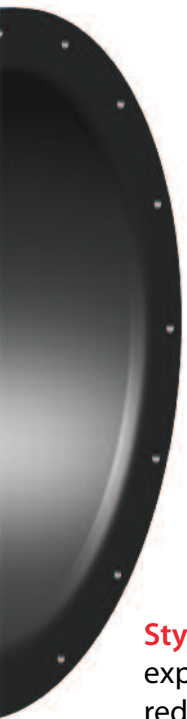

Styles 1092 and 1097 Rubber Flanged Standard ducting expansion joints are designed with lower spring rates for reduced reaction forces and greater movement capabilities within a compact body. This lightweight construction is optimally designed with external or internal molded flanges and represents the most cost-effective arrangement for low pressure flanged ducting applications.

PTFE Single Layer



Style 1093 offers up to 600°F with ± 3 PSI continuous service and zero porosity in wet and dry systems.

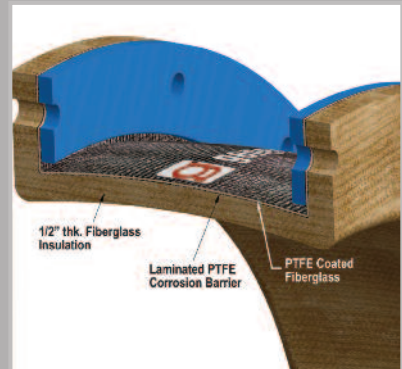

Style 1094 offers up to 1,000°F and ± 3 PSI continuous service.



Style 1095 offers up to 500°F with ± 3 PSI continuous service, zero porosity in wet and dry systems, and a cycle life in the millions.

Spray Shields and Covers



General Rubber's **Style TSS** spray shields safely deflect harmful leakage occurring from flanges, valves and expansion joints. They are available in solid fluoroplastic PTFE construction for superior chemical resistance. In addition to their safety capabilities, spray shields may also be used as solar covers by protecting rubber expansion joints from UV exposure, and to prolong their useful service life.



Expansion Penetration Seals

Style EPS seals pipes through walls, floors and casings with excellent all-directional movement capability offering 20 PSI (40 feet of head) and 250°F service. They are available in flanged or slip-on designs in a wide variety of materials of construction. Custom designs available for larger movements, higher pressure and/or higher service temperatures. Split wrap designs are available for field installation around existing penetrating pipe applications. Additionally, they absorb noise, vibration, pipe misalignment, thermal movements, ground settlement and seismic displacements.



Visit general-rubber.com
for our animated demos.

Flex-Valve® Pinch Valves

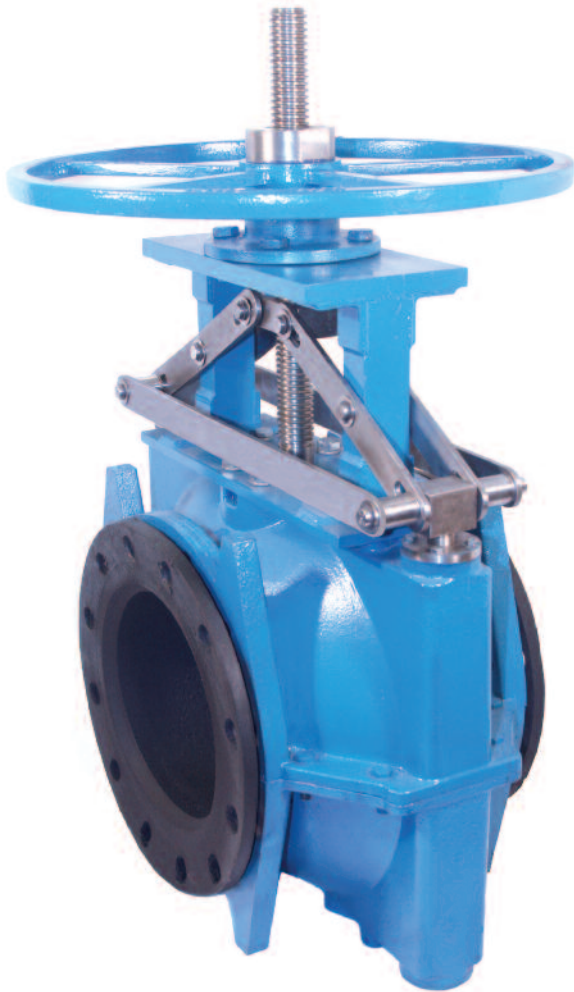

Flex-Valve is a brand under General Rubber Corporation representing our state-of-the-art line of pinch valves and duck bill check valves. It was founded with the purchase of the pinch valve division of Farris Valve, which held the patent on the original pinch valve. With the technical support of General Rubber, later acquisitions, and the addition of new and patented pinch and check valves, Flex-Valve has become a worldwide recognized brand and leading manufacturer in the industry.

The original pinch valve is abrasion and corrosion resistant, non-clogging, maintenance free, and can seal drop tight even on solids. Catering to the demanding conditions of slurries and other difficult fluids, the Flex-Valve pinch valve can outperform alternative products 10 to 1. Many styles have common lengths with plug, gate, and ball valves for interchangeability. The product is available with customized actuators, controls, and sleeve types. Since the sleeve is the only part exposed to the process fluid, it eliminates the need for expensive body alloys.

Visit general-rubber.com for our full line of pinch valves and duck bill check valves.



Flex-Valve® Duck Bill Check Valves

Flex-Valve's duck bill check valves eliminate backflow and seals around entrapped solids.

When used for storm water outfall/overflow systems, the valves provide quiet, maintenance-free operation with the added benefit of low opening pressure, thereby eliminating standing water—a major health concern. When used for submerged outfall diffuser systems, they eliminate marine fouling and backflow intrusion with the added benefit of higher jet velocities even at low flow rates, providing a more uniform port discharge distribution.



The versatile construction of these valves is enhanced by the skills of our creative design team. We can adapt our check valves for additional applications including water mixing systems, overflow vents, anti-siphon devices, coarse bubble diffusers, floor drains, sparging devices, and even, when needed, to increase back-pressure in a pipeline.

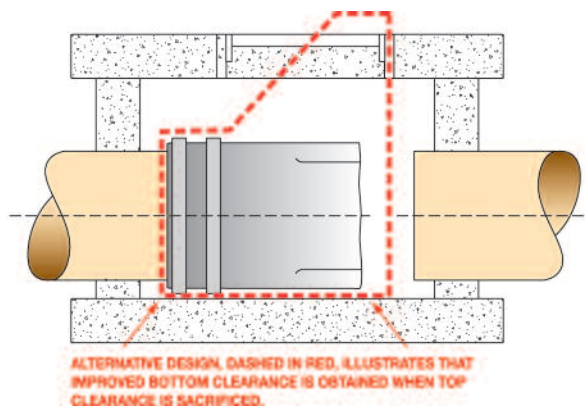
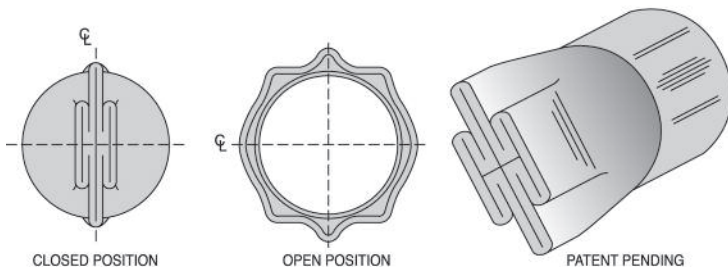

Industries & Sectors

Since 1950, General Rubber has proudly worked across multiple industries and sectors creating performance products for even the most demanding applications. From nuclear and fossil power applications to municipal water supplies and chemical processing plants, General Rubber products are known for their performance, quality and reliability.

Engineering, Procurement, Construction (EPC)

From the world's largest common cooling water system (Ras Laffan, Qatar) to multiple AP1000 nuclear plants (VC Summer 2,3 and Vogtle 3,4), General Rubber collaborates with leading EPC firms and understands the demands of large international new construction projects. Review our BPPO program to see how we support this important market segment.

Maintenance, Repair, Operations (MRO)

With an installed capacity across multiple industries and sectors dating back to 1950, General Rubber is a leader in developing MRO solutions. Specifically, we believe providing performance replacement expansion joints and educating our customers is the best way to ensure the continued efficiency, safety, and reliability of their plants. Review our PREP program to see how we support this important market segment.

Original Equipment Manufacturers (OEM)

General Rubber is dedicated to providing technical sales and support to original equipment manufacturers around the world, providing unique, value-added solutions, ranging from the simple to the simply amazing. Review our OEM Solutions to see how we support this important market segment.



General Rubber focuses on these industries:

- Power – Fossil and Nuclear
- Chemical Processing
- Wastewater
- Mining and Mineral Processing
- Pulp and Paper Processing
- Steel
- Marine
- HVAC



Resources

General Rubber offers a wide range of resources to support our customers across multiple industries and sectors. We believe it is critical to not only provide technical training, but enrich our clients with detailed product literature, application tools, and educational materials, to help them make the best and most informed decisions. These resources can quickly be located on our website, and most are available for download and/or print.

- Features & Benefits
- Materials of Construction
- Selection & Application
- Catalogs
- Data Sheets
- Guideline Specifications
- Installation & Maintenance Instructions
- Application Demos
- Solid Model Images
- Flange Data
- Case Studies

Visit us at
general-rubber.com
 today!

Technical Articles

We are proud to collaborate with leading industry periodicals including Pumps & Systems, WaterWorld, Maintenance Technology and Pump Engineer to provide expert guidance on the features and benefits of our performance products, their selection and application, and implementing an efficiency and reliability program.

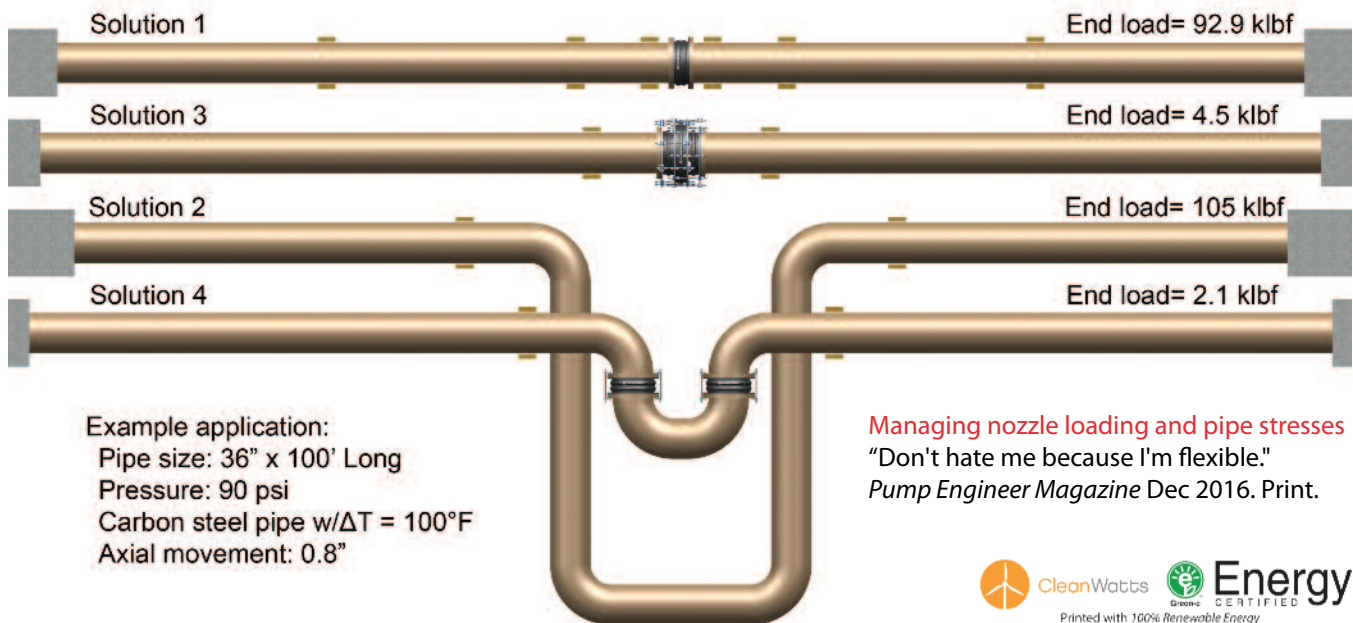

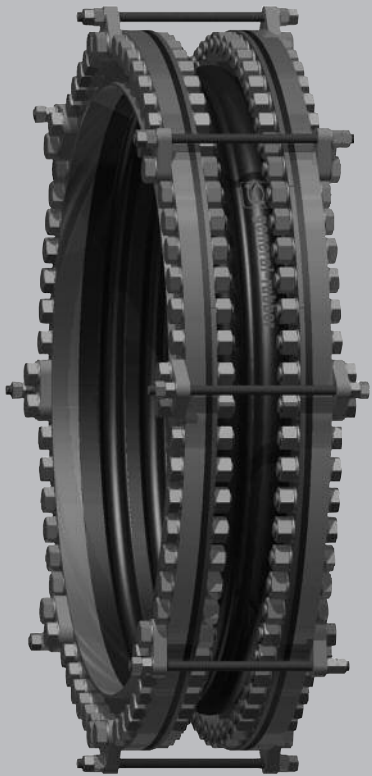

© 1950–2019
General Rubber Corporation.
All Rights Reserved.

The information presented in this catalog is provided in good faith. General Rubber Corporation reserves the right to modify or improve its design specifications without notice and does not imply any guarantee or warranty for any of its products from reliance upon the information contained herein. For specific application recommendations, consult General Rubber Corporation. Failure to properly select products could result in property damage and/or serious personal injury. All orders are subject to final acceptance by General Rubber Corporation.

Viton®, Hypalon®, Teflon® and Kevlar® are registered trademarks of DuPont Performance Elastomers.



Phone: 941-412-0001
Toll Free: 800-233-6294



printed on
recycled paper

FOR OVER 65 YEARS

General Rubber has proudly worked across multiple industries and sectors, providing powerful solutions to even the most demanding applications.

We are particularly proud of both our EPC-focused program for Best Piping Practice and Optimization (BPPO), and our MRO-focused Plant Reliability and Efficiency Program (PREP).

In addition, utilizing advanced materials and technologies has differentiated us as a leader in the industry and is the principal reason our products range "From the Simple to the Simply Amazing."

general-rubber.com