



general rubber  
**Flex-Valve®**



# TECHNICAL GUIDELINES



**ISO 9001:2000  
CERTIFIED**



**New Jersey Operation**

Since our inception in 1950, General Rubber Corporation has provided engineered solutions utilizing mechanical rubber products in a wide range of demanding applications. Rubber is extremely compliant and durable, making it an ideal material for car tires, expansion joints, resilient supports, **Pinch Valves and Duck Bill Check Valves**. We are experienced at incorporating advanced materials and technologies to what some may consider a mature product line, resulting in improved performance and solutions to a wider range of demanding applications.

**Flex-Valve®** is a brand under General Rubber Corp. representing our various valves and other slurry products. Flex-Valve was founded with the purchase of the pinch valve division of Farris Valve, which held the patent on The Original Pinch Valve. With the technical support of General Rubber, later acquisition of the Ray Wilcox Company and the addition of new and patented pinch and check valves, Flex-Valve has become a worldwide recognized brand and leading manufacturer in the industry.

**The Original Pinch Valve** is at once simple and ingenious. Developed to handle corrosive and abrasive water in flooded coal mines of Eastern Pennsylvania, the operators could restrict flow by using a pinching mechanism to bear down on a rubber sleeve. That simple idea now serves as the basis for more sophisticated products. We carry a full line of **Non-Plug Valves®** for on/off or modulating service that are non-clogging and resistant to abrasive, corrosive, and scaling fluids. They are ideally suited for difficult slurries and other demanding applications. Many styles have common lengths with Plug, Gate, and Ball Valves for interchangeability. The product can close drop-tight on solids and is available with customized actuators, controls, and port sizes. The sleeve is the only part exposed to the process fluid and can eliminate the need for expensive body alloys.

The flow pattern of Flex-Valve's pinch valves are inherently streamlined making them well suited for modulating service, however sizing then becomes critically important. For an on/off valve, port sizing is a simple case of maximum flow. If it is determined that a smaller valve can be used, the benefit is primarily economic. For a



Formula 1  

$$C_v = Q * \sqrt{G_f / \Delta P_{act}}$$

Formula 2  

$$\Delta P_{all} = F_L^2 * (P_1 \text{ psig} + 14.7 - .93 * P_v)$$

modulating valve, our **Control Pinch Valve**, port sizing is critically important for performance reasons and both maximum and minimum flows must be considered. The port must be sized to handle the maximum flow; however it is equally important to consider minimum flow so that the valve is not oversized. At minimum flow, an oversized port would need to operate near its fully closed position. This is a problematic position because the once round port is now completely flattened with a very shallow space remaining. This wide but very shallow space becomes



Series 2100 replaces gate, plug, and ball valves and is ideal for manual isolation.



Style 2200EA is ideal for electric control of abrasive, corrosive, viscous, or scaling fluids.



Style 2200PA with positioner is ideal for pneumatic modulation of all slurries.

Style 2300HA – this 16" diameter has a 16 3/4" length making it interchangeable with a Plug Valve of that size.





a wear location as slurries have to pass through it. Another concern associated with this problematic position is that small movements in the actuator will result in large changes in flow. If the shallow space is only 1/4" for example, a 1/8" movement in actuation would have nearly a 50% affect on flow. This sensitivity is too tight resulting in the actuator constantly hunting for its ideal position. This constant hunting will cause terrible wear on both the actuator and the valve internals. Ideally, the valve should be sized to less than 60% closed at minimum flow. In this position, the now oval port has good rangability with improved life of the actuator and valve internals.

**Sizing the pinch valves** is technically done using the ISA's two formula method. The  $C_v$  (formula 1) is first calculated using the actual change in pressure across the system  $\Delta P_{act}$ . If the allowable change in pressure across the system  $\Delta P_{all}$  (formula 2) is calculated to be less than  $\Delta P_{act}$ , it must be substituted in the original  $C_v$  formula. Cavitation may occur if  $\Delta P_{act}$  is greater than  $\Delta P_{all}$ . Cavitation is a serious condition and while a funnel sleeve may be used to transfer its damaging effects beyond the pinch valve, other system changes may represent a more effective system-wide solution. To maximize sleeve life, the inlet velocity should also be held below 22 ft/sec or ideally below 14 ft/sec. Our engineers enjoy discussing the intricacies of various applications, and are prepared to size and specify an optimal valve for each application.

Flex-Valve's **Duck Bill Check Valves** eliminate backflow and seals around entrapped solids. When used for storm water outfall/overflow systems, they provide quiet, maintenance-free operation with the added benefit of low opening pressure, thereby eliminating standing water – a major health concern. When used for submerged outfall diffuser systems, they eliminate marine fouling and backflow intrusion with the added benefit of higher jet velocities. The higher jet velocities are also achieved at low flow rates ensuring uniform port discharge distribution. The versatile construction and our creative design team can adapt the Duck Bill Check Valve to a wide range of applications including: water mixing systems, overflow vents, anti-siphon devices, coarse bubble diffusers, floor drains, sparging devices, or when needed, a device to increase back pressure in a pipe line.

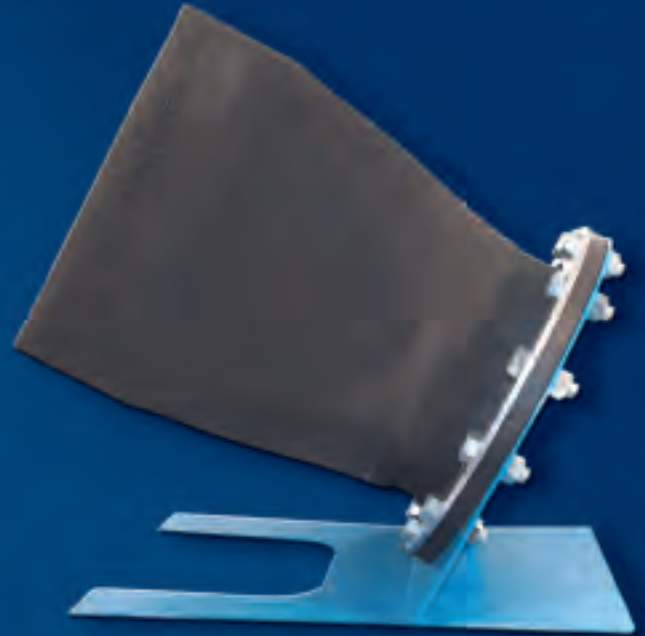

**General Rubber Corporation** has extensive experience working in municipal and industrial wastewater treatment plants, as well as nuclear power plants, chemical processing plants and many other mining and industrial operations worldwide. With our modern U.S. ISO 9001:2000 Certified manufacturing facility and top engineering staff, we are confident we can exceed the demands of your application. Thank you for your consideration.

Warm regards,

**Lloyd B. Aanonsen, P.E.**  
President

*For a complete line of Expansion Joints, as well as noise and vibration control products, see General Rubber's Maxi Joint® and SoundZorber® Technical Guideline Catalogs.*



*Style 9500A is a tube and shell design and is economic, lightweight, and ideal for low pressure applications.*



*Style 5500 Pressure Isolation Ring features a non-clogging gauge and/or pressure switch ideal for slurries.*



*Style 1015 has a wide flowing arch with exceptional movement capability.*



*Style 1092 is available in a wide range of materials and allows for needed flexibility in ducting systems.*



*“From the simple, to the simply amazing.”*

**Features:**

**NON-CLOGGING:** The Flex-Valve sleeve is self-cleaning due to its unobstructed design and flexing action. Flex-valves will not jam or seize, even with high-percent solids.

**ABRASION AND CORROSION RESISTANT:** Flex-Valve’s high-grade elastomer sleeves outperform metal valves in abrasion and corrosion. The sleeve is the only part of the pinch valve exposed to the process fluid, making it a cost-effective alternative to valves constructed of exotic body alloys.

**MAINTENANCE-FREE:** The operating mechanism of the Flex-Valve is isolated from the process fluid, virtually eliminating any wearing or seizing issues. This is also why the torque to close a Flex-Valve remains constant over time, even when the valve has not been exercised.

**SEALS DROP-TIGHT EVEN ON SOLIDS:** The thick elastomer tube of the Flex-Valve sleeve forms around entrapped solids and seals drop-tight without damage to the sleeve.

**MODULATING SERVICE:** The smooth unobstructed sleeve contour minimizes turbulence even when throttled. Reduced port sleeves are available in double wall, hour glass and funnel types to match flow rates and process conditions.

**INTERCHANGEABILITY:** Many Flex-Valve styles have common lengths with Plug, Gate, and Ball Valves, making them ideally suited for retrofit and plant upgrade applications.

**VERSATILE AND MODULAR CONSTRUCTION:** The Flex-Valve design enables the customer to choose the sleeve material and type of valve body construction, as well as any customized actuators and/or controls. Many designs allow the customer to change the actuator type even while the valve is in service.

**COST-EFFECTIVE SOLUTION:** An optimal design does not necessarily mean higher pressure or temperature ratings, because these features typically increase the product’s cost and maintenance. General Rubber will work with your system requirements, and with over 50 years of experience, we feel confident that we can develop an optimal and cost-effective solution for even the most demanding applications. Our abrasion and corrosion-resistant materials can outperform even the most exotic metals. Our large inventories and modern U.S. ISO 9001:2000 certified manufacturing facility also mean quick deliveries and top quality.



*Style 2200 shown with high visibility position indicator.*

**WATER & WASTEWATER TREATMENT**

- Raw Sewage
- RAS & WAS Handling/Control
- Carbon Slurry
- Flow Equalization
- Grit Systems
- Influent & Effluent
- Lime Feed Control
- Pump Isolation
- Polymer Feed

**Applications:**

**PAPER & PULP**

- Bleaching Systems
- Pulp & Recycled Paper
- Liquid Flow Control



*Style 2300 is interchangeable with Plug Valves in all sizes.*



*Style 4100 is our Slip-on type Duck-Bill Check Valve.*



*Style 4200 is our flanged type Duck-Bill Check Valve.*

*Style 2200DA features a diaphragm actuator for sensitive flow control and can be installed in any position.*



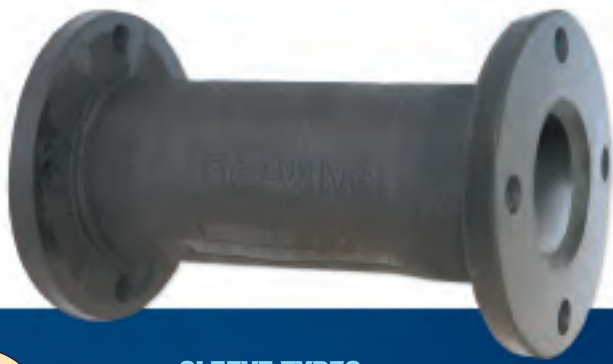

### SLEEVE TYPES:

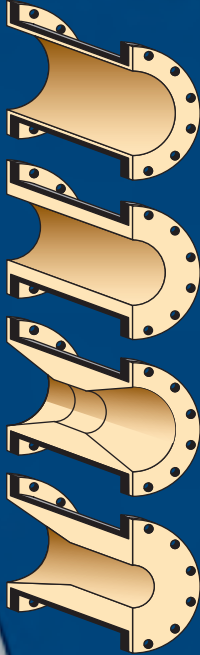

**STANDARD SLEEVE:** Features a 100% full port through entire length with a wide variety of high-quality elastomers and reinforcements.

**DOUBLE WALL SLEEVE:** Designed for extremely abrasive service. It has three times the tube thickness of our standard sleeve and is also a rugged and effective way to reduce the port diameter.

**HOURLASS SLEEVE:** Designed for flow control applications. The reduced port is centered in the sleeve and is sized to match the calculated flow conditions.

**FUNNEL SLEEVE:** Also designed for flow control applications. The reduced port in this sleeve extends from the center of the sleeve through the discharge end and helps to reduce cavitation within the valve body.

### Materials of Construction:

**PURE GUM RUBBER:** Excellent resilience and rebound elasticity with high tensile strength. Excellent resistance to tear and abrasion. Effective operating range from -40°F to 180°F.

**NEOPRENE:** Resists alkalis, inorganic acids, and salt solutions. Flame-retardant, as well as abrasion and weather resistant. Good resistance to animal and vegetable oils; moderate resistance to petroleum oils. Effective operating range from -20°F to 225°F.

**CHLOROBUTYL:** Lowest permeability, very good resistance to water, heat, fats, ozone, alkalis, sunlight, abrasion, and oxygenated solvents. Effective operating range from -30°F to 300°F with brief excursions to 350°F.

**HYPALON®:** Offers superior weather resistance, flame retardant, good abrasion resistance, and excellent resistance to acids, alkalis, and oxidation. Effective operating range from -10°F to 250°F.

**BUNA-N (NITRILE):** Good resistance to mineral and vegetable oils, greases, hydrocarbon solvents, dilute acids, and alkalis. Effective operating range from -10°F to 210°F.

## Industry-Leading State-of-the-Art Construction Materials.

### Applications:

#### MINING

- Tailings & Slurries
- Cyclone Separation
- Lime Control
- Leaching Processes
- Solid Separation
- Slurry Control to Flotation Cells
- Thickener Underflow
- Dust Collection Systems

#### FOOD & PHARMACEUTICAL

- Weighing Systems
- Filling Systems
- Processing Systems
- Potable Water
- Sugar Processing

#### POWER

- FGD (Flue Gas Desulfurization) Scrubber Systems
- Fly & Bottom Ash Handling
- Lime & Limestone Transportation
- Ash Slurry pH Control
- Coal Handling
- Geothermal Brine

#### CHEMICAL

- Painting Systems
- Lime Addition or pH Control
- Industrial Chemical Treatment
- White Pigment (TiO2)
- Dirty & Viscous Chemicals
- Powders, Synthetic Fiber Pneumatic Systems

#### CONVEYING

- Cement
- Sand
- Food
- Fertilizers
- Powders

**EPDM:** Outstanding water, vapor, and weather resistance. Good resistance to heat, ozone, alkalis, sunlight, and oxygenated solvents. Ideal for outdoor service. Do not use with petroleum oil service. Good general purpose elastomer for an effective operating range from -30°F to 350°F.

**FDA FOOD-GRADE SERVICE:** Several white and black elastomers meet FDA requirements and can be used in direct contact with food, beverage, and pharmaceutical products.

**VITON®:** Excellent resistance to aggressive chemicals, solvents, and halogenated hydrocarbons. Viton® TBR-S provides excellent resistance to steam, aqueous acids, amines and concentrated caustics/bases/alkalies. Viton® ETP-S offers the most universal chemical resistance and has excellent flexibility at low temperatures. Effective operating range from -10°F to 400°F.



**REINFORCEMENTS:** Polyester, Nylon, Kevlar®, fiberglass, and steel. Temperature rating is dependent on both elastomer and reinforcements.



Style 9500XL ranges from 10" to 72" in diameter. Call the factory for more details.



Style 2150/7250 is the valve of choice for abrasive and corrosive service in mining applications.



Style 2300PA has a 100% full port with pneumatic actuation.



Style 7100 is a slip-on type valve adaptable to a variety of process applications.

# Flex-Valve®

## Manual Pinch Valve

### Series 2100

#### Features:

- Enclosed body design
- Conforms to ANSI B16.10 lengths, making it interchangeable with Gate, Plug, and Ball Valves
- Cost effective
- Dual pinching mechanism closes from top and bottom to center
- Position indicator standard
- 100% full port eliminates clogging and turbulence while minimizing pressure drops
- Vertical enclosure split line for complete accessibility to all internal components
- Nonrising handwheel and stem
- Operating torques will remain constant over time, even when left open or closed for years
- Prevents scaling buildup and clogging with its unobstructed design and flexing action
- Rubber sleeve is the only part exposed to the process fluid
- Drop-tight bi-directional closure, even on solids
- Flanges tapped for ANSI 125/150 lb.
- Full flat-faced integral elastomer flanges
- Can be installed in any position
- Positive opening device standard
- No packing, gaskets or seals to maintain
- The isolation valve of choice for most wastewater treatment plants and many light industrial plants

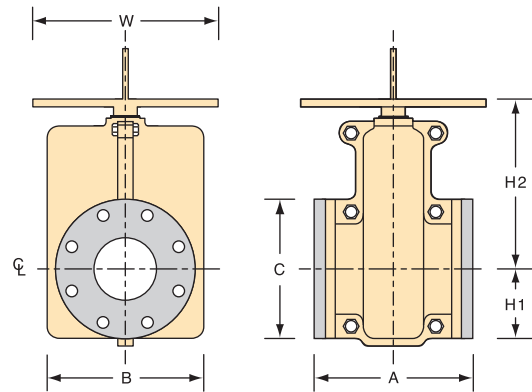

SERIES 2100 VALVE SIZE	D I M E N S I O N S							
	1	1-1/2	2	2-1/2	3	4	6	8
A	5-1/2	6-1/2	7	7-1/2	8	9	10-1/2	11-1/2 or 16
B	5-1/4	5-3/8	7-1/8	6-7/8	8-1/4	9-1/2	13	18-1/2
C	4-1/4	5	6	7	7-1/2	9	11	13-1/2
H1	2-1/8	2-1/2	3	3-1/2	3-1/4	4-1/2	5-1/2	6-3/4
H2	7-9/16	7-9/16	9-3/8	9-3/8	10-1/2	12	15	18-1/2
W	8	8	8	8	8	12	18	22
Max. Pressure (PSIG)	150	150	150	150	150	150	150	125
Approx. Weight (Lbs.)	17	25	36	43	52	83	135	260 or 320

Notes: 1) For full product specifications and installation instructions, see SPEC2100-1 and ININ2100-1, respectively. 2) All dimensions expressed in inches. Contact General Rubber for sizes not shown and higher pressure ratings. 3) WARNING: Pinch valves may operate in pipelines carrying fluids at elevated temperatures and pressures, so precaution should be taken to ensure proper installation and regular inspection. Care is required to protect personnel in the event of leakage or spray. Adequate floor drains for indoor applications are always recommended.



# Flex-Valve®

## Manual Pinch Valve

### Style 2150 & 7250

#### Features:

- Open body design
- Style 2150 conforms to ANSI B16.10 lengths making them interchangeable with Gate, Plug, and Ball Valves
- Style 7250 has a longer length sleeve for reduced stress and longer service life
- Available in custom face to face lengths
- Rugged, lightweight and economical
- Dual pinching mechanism closes from top and bottom to center
- Operating positions clearly visible
- 100% full port eliminates clogging and turbulence while minimizing pressure drops
- Operating torques will remain constant over time, even when left open or closed for years
- Prevents scaling buildup and clogging with its unobstructed design and flexing action
- Rubber sleeve is the only part exposed to the process fluid
- Drop-tight bi-directional closure, even on solids
- Flanges drilled for ANSI 125/150 lb.
- Full flat-faced integral elastomer flanges
- Can be installed in any position
- Positive opening device available
- No packing, gaskets or seals to maintain
- The valve of choice for most mining applications, including heavy slurries in tailing lines

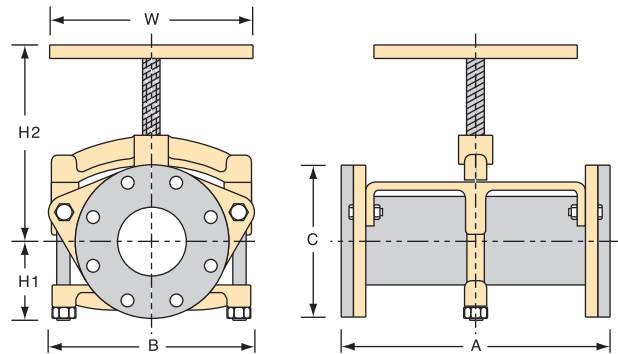

STYLE 2150 & 7250 VALVE SIZE	D I M E N S I O N S														
	1	1-1/2	2	2-1/2	3	4	6	8	10	12	14	16	18	20	24
2150 A	5-1/2	6-1/2	7	7-1/2	8	9	10-1/2	16	20	24	28	32	36	40	48
7250 A	4	6	8	10	12	16	24	32	40	48	42	48	54	60	72
B	6	7	8-7/16	9-5/16	10-3/4	12-1/4	15-7/8	20-1/8	27-3/4	27-3/4	30-1/2	33-1/2	43	45	48
C	4-1/4	5	6	7	7-1/2	9	11	13-1/2	16	19	21	23-1/2	25	27-1/2	32
H1	2-1/8	2-1/2	3	3-1/2	3-3/4	4-1/2	5-1/2	6-3/4	8	9-1/2	10-1/2	11-3/4	12-1/2	13-3/4	16
H2	5	6-5/8	7-11/16	9-1/8	10-1/4	12-5/16	19-1/2	23-3/4	27-1/2	32	37	41	46	50	55
W	4	4	8	8	8	12	18	22	22	22	22	22	22	22	22
Max. Pressure (PSIG)	150	150	150	150	150	150	150	125	100	100	75	50	50	50	50
Approx. Weight (Lbs.)	5	10	17	25	37	55	140	225	310	460	610	720	740	760	820

Notes: 1) For full product specifications and installation instructions, see SPEC2150-1, SPEC7250-1 and ININ2150-1, ININ7250-1, respectively. 2) All dimensions expressed in inches. Contact General Rubber for sizes not shown and higher pressure ratings. 3) WARNING: Pinch valves may operate in pipelines carrying fluids at elevated temperatures and pressures, so precaution should be taken to ensure proper installation and regular inspection. Care is required to protect personnel in the event of leakage or spray. Adequate floor drains for indoor applications are always recommended.



# Flex-Valve®

## Manual, Electric and Pneumatic Control Pinch Valves

### Series 2200

#### Features:

- Enclosed body design
- Conforms to ISA control pinch valve standard S75.08
- Modular design for easy conversion, even in-line, between manual, electric, and pneumatic actuation
- Nonrising actuation for safety and ridged connections
- Operating torques will remain constant over time, even when left open or closed for years
- Available completely sealed with body mounted gauge or pressure switch for fugitive emissions, submerged or buried service
- Prevents scaling buildup and clogging with its unobstructed design and flexing action
- Rubber sleeve is the only part exposed to the process fluid
- Drop-tight bi-directional closure, even on solids
- Flanges tapped for ANSI 125/150 lb.
- Full flat-faced integral elastomer flanges
- Can be installed in any position
- Positive opening device standard
- No packing, gaskets or seals to maintain
- The control valve of choice for most wastewater treatment plants and light industrial plants

### Style 2200EA Electronic Actuation

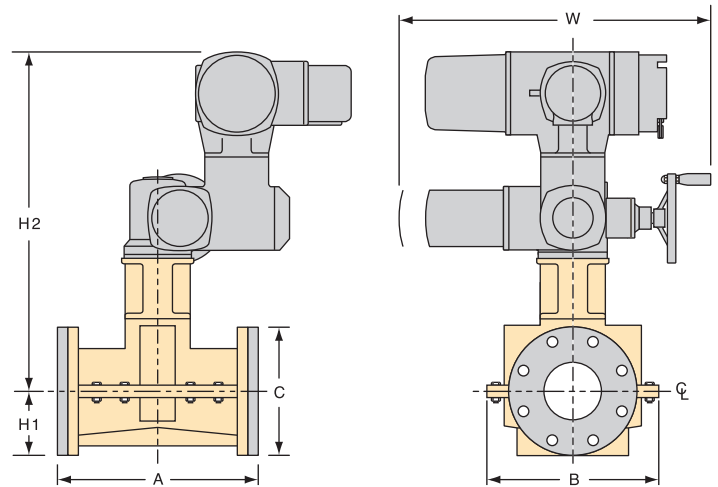
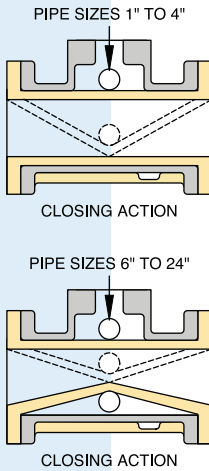

### Style 2200 Manual Actuation

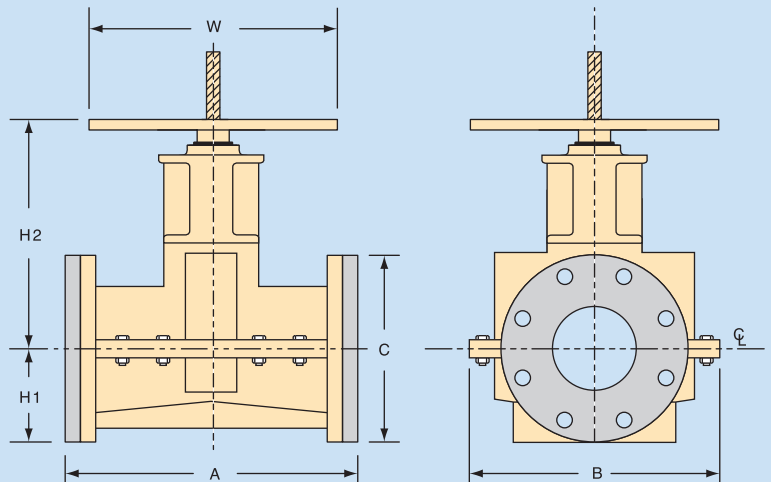



VALVE SIZE	DIMENSIONS														
	1	1-1/2	2	2-1/2	3	4	6	8	10	12	14	16	18	20	24
Max. Pressure (PSIG)	150	150	150	150	150	150	150	125	100	100	75	50	50	50	50
2200															
A	7-1/4	8-3/4	10	10-7/8	11-3/4	13-7/8	18	21-3/8	26-1/2	29	28	32	36	40	48
B	6-1/2	6-1/2	8-1/4	8-1/4	9-1/2	12-1/2	14	18	22-7/8	26-1/4	32	37	44	47	52
C	4-1/4	5	6	7	7-1/2	9	11	13-1/2	16	19	21	23-1/2	25	27-1/2	32
H1	2-1/8	2-1/2	3	3-1/2	3-3/4	4-1/2	5-1/2	6-3/4	8	9-1/2	10-1/2	11-3/4	12-1/2	13-3/4	16
W	8	8	8	8	12	12	18	22	BG	BG	BG	BG	BG	BG	BG
H2	8	8	9	9	11	11-1/2	16	17	19	21	25	29	34	38	41
Approx Weight (Lbs)	17	38	50	65	76	125	235	305	615	850	950	1100	1300	1420	1900
2200EA															
W	19-1/2	19-1/2	20-1/2	20-1/4	21-1/4	28	28	34	34	34	34	36-1/2	36-1/2	36-1/2	41
H2	29	29	29	29	30	35	36	37	40	40	42	44	47	50	55
Approx Weight (Lbs)	85	135	170	200	230	350	440	670	800	995	1500	1900	2650	3200	3900
2200PA															
W	*	*	*	*	*	*	*	*	*	*	*	*	*	*	*
H2	17	19	21	23	26	32	40	43	46	53	55	57	59	62	70
Approx Weight (Lbs)	42	47	80	83	100	175	220	650	990	1340	1400	1600	2000	2500	4300
2200DA															
W	8-1/2	8-1/2	15	15	18	18	26	26	N/A	N/A	N/A	N/A	N/A	N/A	N/A
H2	10-1/2	10-3/4	11-1/2	12	16	16-1/2	20	21	N/A	N/A	N/A	N/A	N/A	N/A	N/A
Approx Weight (Lbs)	30	45	75	90	110	150	260	320	N/A	N/A	N/A	N/A	N/A	N/A	N/A

Notes: 1) BG - Bevel Gear installed on Pinch Valve. 2) Width of cylinder is dependent upon process line pressure. Some valves shown with optional accessories. 3) For full product specifications and installation instructions, see SPEC2200-1, SPEC2200EA-1, SPEC2200PA-1 and ININ2200-1, ININ2200EA-1, ININ2200PA-1, respectively. 4) WARNING: Pinch valves may operate in pipelines carrying fluids at elevated temperatures and pressures, so precaution should be taken to ensure proper installation and regular inspection. Care is required to protect personnel in the event of leakage or spray. Adequate floor drains for indoor applications are always recommended.

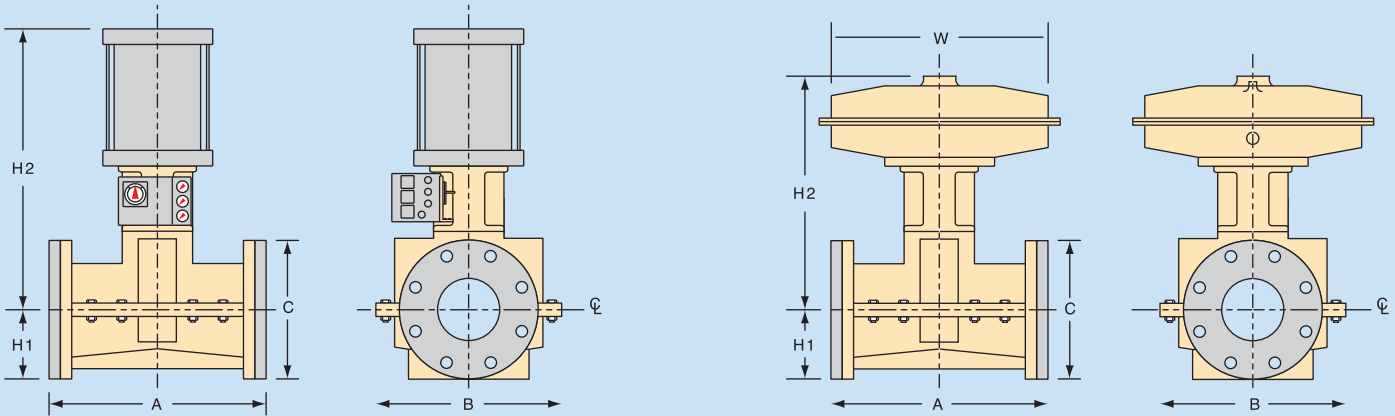

DIMENSIONS BASED UPON ATO/ATC CYLINDER AND ARE FOR REFERENCE ONLY.



Style **2200PA**  
Cylinder Actuation



Style **2200DA**  
Diaphragm Actuation



# Flex-Valve®

## Manual, Electric and Pneumatic Interchangeable Pinch Valves

### Series 2300

#### Features:

- Enclosed body design
- Interchangeable with Plug Valves in all sizes
- Modular design for easy conversion, even in-line, between manual, electric and pneumatic actuation
- Dual pinching mechanism closes from top and bottom to center
- 100% full port eliminates clogging and turbulence while minimizing pressure drops
- Nonrising actuators for safety and rigid connections
- Operating torques will remain constant over time, even when left open or closed for years
- Available completely sealed with body mounted gauge or pressure switches for fugitive emissions, submerged or buried service
- Prevents scaling buildup and clogging with its unobstructed design and flexing action
- Rubber sleeve is the only part exposed to the process fluid
- Drop-tight bi-directional closure, even on solids
- Flanges tapped to ANSI 125/150 lb.
- Full flat-faced integral elastomer flanges
- Can be installed in any position
- Positive opening device standard
- No packing, gaskets or seals to maintain
- This versatile retrofit valve is ideal for many plant upgrades and modernization projects



Style 2300  
Hand Wheel Actuation

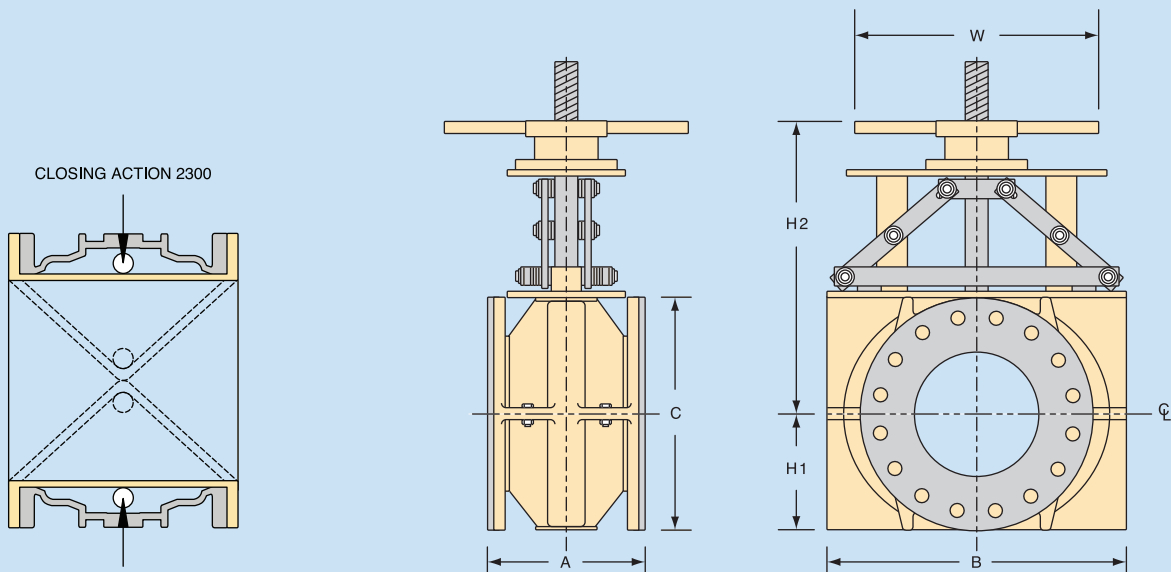

# The Non-Plug Valve® Interchangeable with Plug Valves in All Sizes

VALVE SIZE	DIMENSIONS									
	4	6	8	10	12	14	16	18	20	24
<b>2300</b>										
A	9	10-1/2	11-1/2	13	14	17	17-3/4	21-1/2	23-1/2	42
B	16	20	23	25	28	32	37	41	45	50
C	9	11	13-1/2	16	19	21	23-1/2	25	27-1/2	32
H1	4-1/2	5-1/2	6-3/4	8	9-1/2	10-1/2	11-3/4	12-1/2	13-3/4	16
W	12	18	22	BG	BG	BG	BG	BG	BG	BG
H2	16	19	20	22	24	28	32	33	36	46
Approx Weight (Lbs)	86	130	180	250	500	670	750	910	1200	1400
<b>2300EA</b>										
W	28	28	34	34	34	34	36-1/2	36-1/2	36-1/2	41
H2	39-1/2	40	42	50	52	54	55	56	57	69
Approx Weight (Lbs)	360	460	690	840	1050	1450	1800	2120	2300	4060
<b>2300PA</b>										
W	*	*	*	*	*	*	*	*	*	*
H2	40	48	51	54	60	63	65	67	70	78
Max. Pressure (PSIG)	150	150	150	100	100	75	50	50	50	50
Approx Weight (Lbs)	185	245	700	1050	1410	1500	1750	2200	2600	4300

Notes: 1) A bevel gear is recommended for sizes 10" and over for manual service. 2) BG - Bevel Gear installed on Pinch Valve (2300BG). 3) Width of cylinder is dependent upon process line pressure. 4) For full product specifications and installation instructions, see SPEC2300-1, SPEC2300EA-1, SPEC2300PA-1 and ININ2300-1, ININ2300EA-1, ININ2300PA-1, respectively. 5) All dimensions expressed in inches. Contact General Rubber for sizes not shown and higher pressure ratings. 6) WARNING: Pinch valves may operate in pipelines carrying fluids at elevated temperatures and pressures, so precaution should be taken to ensure proper installation and regular inspection. Care is required to protect personnel in the event of leakage or spray. Adequate floor drains for indoor applications are always recommended.

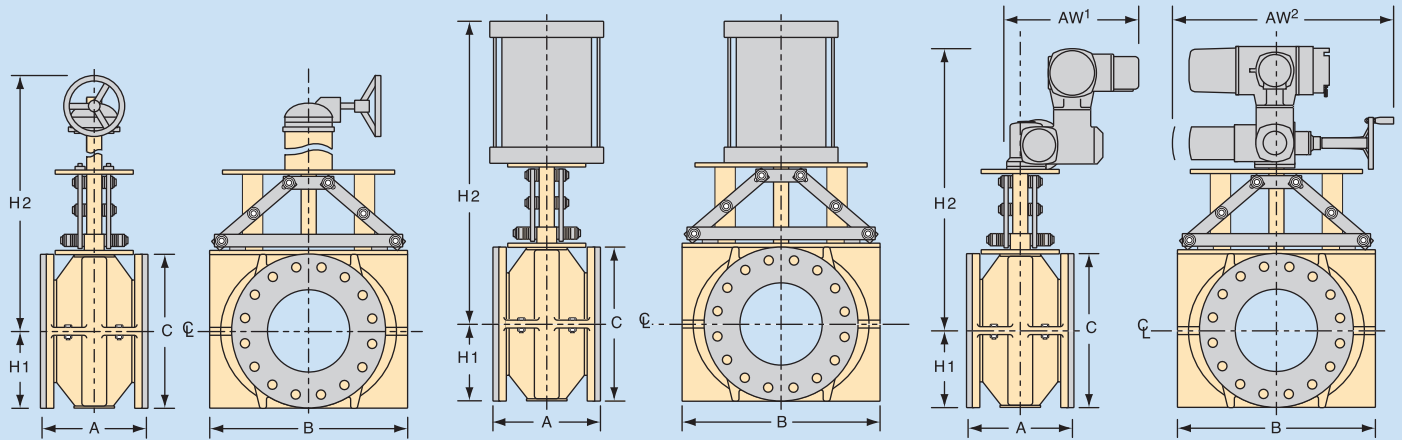

DIMENSIONS BASED UPON ATO/ATC CYLINDER AND ARE FOR REFERENCE ONLY.



**Style 2300BG**  
Bevel Gear Actuation



**Style 2300PA**  
Pneumatic Actuation



**Style 2300EA**  
Electronic Actuation



# Flex-Valve®

## Air Actuation Pinch Valve

### Style 9500A

#### Features:

- Tube and shell design
- Housing acts as a built-in actuator
- Rugged, lightweight and economical
- 100% full port eliminates clogging and turbulence while minimizing pressure drops
- Can be accessorized as an inexpensive non-critical control valve
- Prevents scaling buildup and clogging with its unobstructed design and flexing action
- Full round through entire length
- Rubber sleeve is the only part exposed to the process fluid
- Flanges tapped for ANSI 125/150 lb.
- Full flat-faced integral elastomer flanges
- Can be installed in any position
- All cast members are ductile iron
- Original 9500 sleeves are available as replacement parts
- The valve of choice for most OEM and low pressure applications

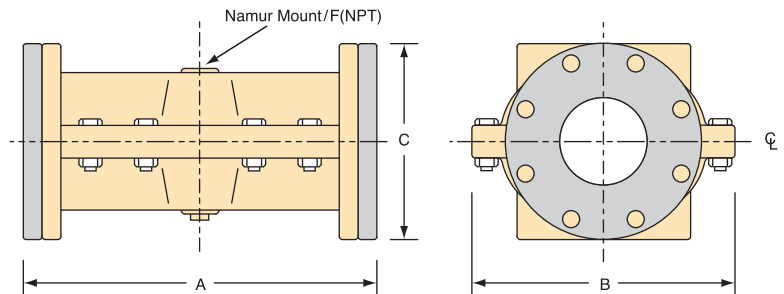

The Series 9500A enclosed type pinch valve is a simple on/off valve that is ideal for use in process applications. The simple structure of this valve consists of two metal casings, an elastomer sleeve, and casing gaskets. The valve is closed by directly injecting air or fluid into the body (casing).

Approximately 35 PSI differential pressure above the line pressure is required to close the valve. The elastomeric sleeve features a flange that requires no gasketing. Most elastomers will allow the valve to seal drop-tight. The 9500XL is available for pipe sizes 10"- 72" diameter. Call the factory for more details.

STYLE 9500A VALVE SIZE	D I M E N S I O N S								
	1	1-1/2	2	2-1/2	3	4	5	6	8
A	5	7	9	10	12	12-1/2	16-1/2	20	22
B	5-3/4	6-5/8	8	8-5/8	9-3/4	12	13-1/2	15-1/2	19
C	4-1/4	5	6	7	7-1/2	9	10-1/4	11-1/2	13-1/2
D	1/4	1/4	1/2	1/2	1/2	1/2	1/2	1/2	3/4
Max. Pressure (PSIG)	50	50	50	50	50	50	50	50	50
Approx. Weight (Lbs.)	10	15	25	32	40	78	110	175	300

12

Notes: 1) Contact factory for sizes up to 72" and for higher working pressures. Previously supplied style 9500 is available as replacement parts and sleeves only. 2) For full product specifications and installation instructions, see SPEC9500A-1 and ININ9500A-1, respectively. 3) All dimensions expressed in inches. Contact General Rubber for sizes not shown and higher pressure ratings. 4) WARNING: Pinch valves may operate in pipelines carrying fluids at elevated temperatures and pressures, so precaution should be taken to ensure proper installation and regular inspection. Care is required to protect personnel in the event of leakage or spray. Adequate floor drains for indoor applications are always recommended.



# Flex-Valve®

## Slip-on Pinch Valves

### Style 7100 & 7500

#### Style 7100 Features:

- Open body design
- Slips-over standard pipe
- Rugged, lightweight and economical
- Available in sizes from 1/2" to 4"
- Operating position clearly visible
- 100% full port eliminates clogging and turbulence while minimizing pressure drops
- Prevents scaling buildup and clogging with its unobstructed design and flexing action
- Full round through entire length
- Rubber sleeve is the only part exposed to the process fluid
- Can be installed in any position
- All cast members are ductile iron
- The valve of choice for most OEM and low pressure applications

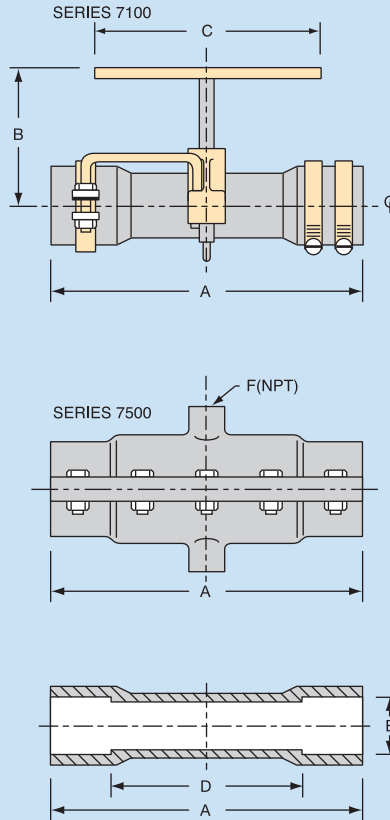

#### Style 7500 Features:

- Tube and shell design
- Slips-over standard pipe
- Housing acts as a built-in actuator
- Rugged, lightweight and economical
- Available in sizes from 1/2" to 2"
- 100% full port eliminates clogging and turbulence while minimizing pressure drops
- Prevents scaling buildup and clogging with its unobstructed design and flexing action
- Full round through entire length
- Rubber sleeve is the only part exposed to the process fluid
- Can be installed in any position
- Ductile iron castings standard
- The valve of choice for most OEM and low pressure applications

**Style 7100**  
Manual/Slip-on



**Style 7500**  
Air/Slip-on



STYLE 7100 & 7500 VALVE SIZE	DIMENSIONS								
	1/2	3/4	1	1-1/4	1-1/2	2	2-1/2	3	4
A	5	6	7	8	11	13	15	20	24
B	4	4-1/2	4-9/16	5-7/16	6-11/16	7-13/16	9-5/16	10-1/4	12-15/16
C	3	3	3	3	4	8	8	8	12
D	2	3	4	5	6	8	10	12	16
E	27/32	1-1/16	1-5/16	1-21/32	1-29/32	2-3/8	2-7/8	3-1/2	4-1/2
F	1/4	1/4	1/4	1/4	1/2	1/2	—	—	—
Max. Pressure (PSIG)	7100 7500	125 50	125 50	125 50	100 50	100 50	100 50	100 —	100 —
Approx. Weight (Lbs.)		2	3-1/2	4	5-1/2	12	15	17	30

Notes: 1) For full product specifications and installation instructions, see SPEC7100-1, SPEC7500-1 and ININ7100-1, ININ7500-1, respectively. 2) All dimensions expressed in inches. Contact General Rubber for sizes not shown and higher pressure ratings. 3) **WARNING:** Pinch valves may operate in pipelines carrying fluids at elevated temperatures and pressures, so precaution should be taken to ensure proper installation and regular inspection. Care is required to protect personnel in the event of leakage or spray. Adequate floor drains for indoor applications are always recommended.



# Flex-Valve®

## Replacement Components

### Parts:

With "Original Pinch Valve" drawings dating back to the 1940's, we operate the world's largest pinch valve spare parts department. Many Flex-Valve styles were "one of's" or discontinued long ago. However, replacement parts are still available. From a simple "O-ring" to an intricate machined part, we have maintained the engineering experience and records to get you up and running again.



### Sleeves:

Flex-Valve can manufacture replacement pinch valve sleeves with original or improved performance characteristics. The sleeve is the most critical component of the pinch valve, and yet its construction and materials can vary significantly. Replacement sleeves are also available for all popular pinch valve brands, and in most cases, will outperform the original equipment. Custom and non-standard sleeves can be manufactured to customer specifications.

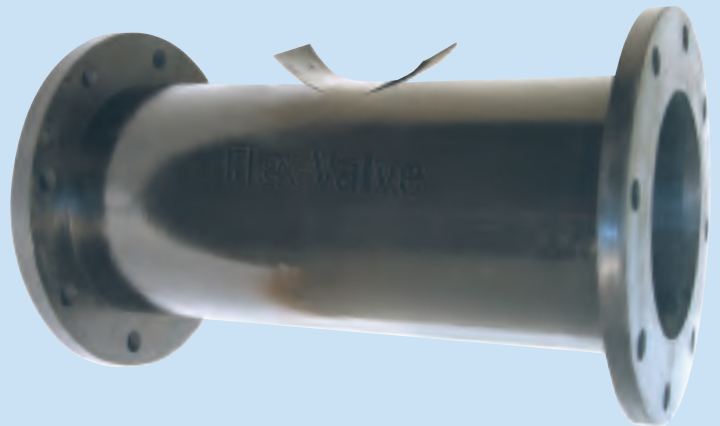

# Flex-Valve®

## Pressure Isolation Rings

### Series 5500-PIR

#### Features:

- No clogging, plugging or fouling of gauges, pressure switches or transmitters
- Excellent for slurries, abrasive fluids and fluids with high percent solids
- Inside diameter matches adjacent pipe for self cleaning or pigging of system
- Gauges can be removed/replaced without interrupting the process or vacuum filled fluid through the use of an integral isolation valve
- Gauges are liquid filled, 2-1/2" diameter, with stainless steel housing and brass bourdon tube

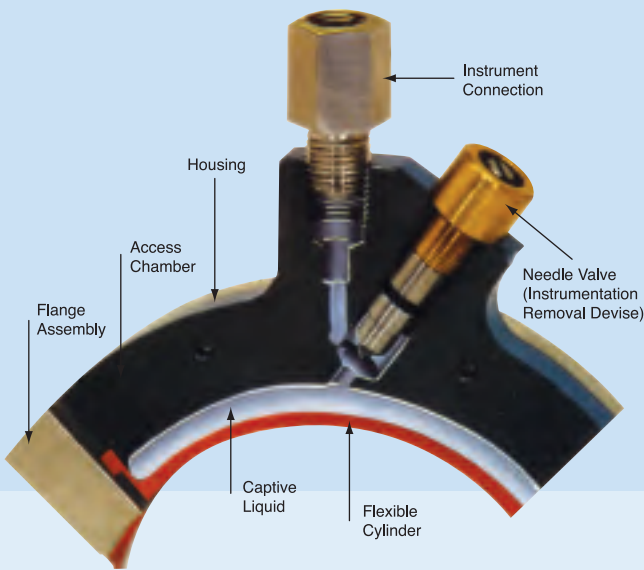

### Series 5500-PIR

#### Pressure Isolation Ring

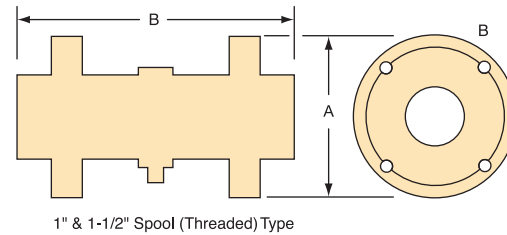
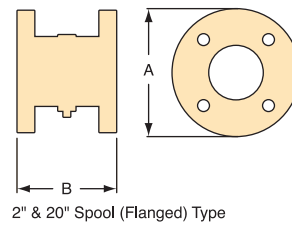
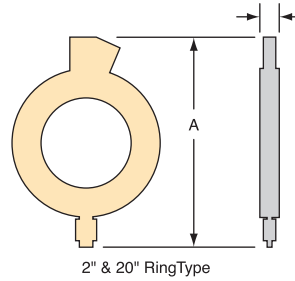

The Series 5500-PIR Pressure Isolation Ring is ideally suited for reliable and accurate pressure reading of abrasive, corrosive, viscous or scaling fluids. The 360° sensing sleeve isolates the gauge or pressure transmitter from the process fluid to prevent clogging. The 5500-PIR isolates and protects gauges,

pressure switches, transmitters and recorders. It can be used for monitoring tank levels, monitoring pressures on long pipe lines to detect breakage, monitoring pressure drops across a filter or pump, measuring the output pressure of a pump, and sending a signal to stop the pump or open a bypass valve.

SERIES 5500-PIR VALVE SIZE	D I M E N S I O N S													
	1	1-1/2	2	3	4	5	6	8	10	12	14	16	18	20
<b>A</b>	4-1/2	5	6-15/16	8-3/16	9	10-1/4	11-3/16	13-3/8	15-9/16	17-9/16	19-15/16	21-15/16	24-3/16	26-1/16
<b>B</b>	5-3/8	5-3/8	2	2	1-1/2	1-1/2	1-1/2	1-1/2	1-1/2	1-3/4	1-3/4	2	2	2
<b>Weight (Lbs.)</b>	8	10	3	6	8	10	12	16	20	25	50	60	70	80

Notes: 1) When using a pressure switch, please specify pressure range, desired set point, and increasing or decreasing for switch contact. 2) Use flange gaskets suitable for the system temperature and fluid media. 3) Gauge and instruments can be removed from unit only while at zero line pressure to prevent permanent displacement of sensing fluid. 4) 1" and 1-1/2" sizes are full 150 lb. flanged spool type; 300 lb. flanged or NPT threaded units are available. Spool type units do not have an integral isolation valve. 5) Gauge and pressure switch shown above are optional. 6) For full product specifications and installation instructions, see SPEC5500-1 and ININ5500-1, respectively.



# Flex-Valve®

## Duck-Bill Check Valves

### Style 4100 Slip-on & 4200 Flanged

#### Features:

- Reliable and cost-effective alternative to flap-gate and other conventional check valves
- Eliminates backflow and seals around entrapped solids
- Rugged all-elastomer construction in a full variety of materials
- Maintenance-free operation with no mechanical components that can corrode or seize
- Lower head loss than conventional check valves
- Will open with as little as 1" W.C.
- Quiet operation (non-slamming)
- Non-plugging
- Excellent corrosion and abrasion resistance
- Versatile construction for a wide range of applications
- Style 4100 is manufactured with an integral reinforced cuff end provided with heavy duty clamps for easy attachment directly over the pipe or thimble plate
- Style 4200 is manufactured with an integral reinforced rubber flange provided with metal retaining rings for easy bolting directly to the pipe flange, tank wall or head wall
- Flanges drilled per standard ANSI B16.1/150 lb. pattern; other drilling patterns are available upon request
- Retaining ring available in galvanized, 304 stainless steel and 316 stainless steel



**Style 4200**  
Flanged Duck-Bill  
Check Valve

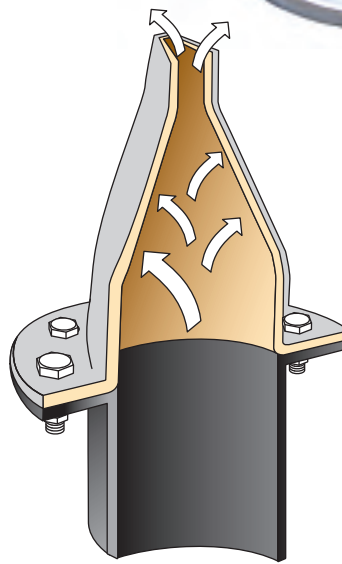

THE FLEX-VALVE® STYLE 4200 CHECK VALVE ILLUSTRATED OPEN WITH LINE PRESSURE TO ALLOW THE PROCESS MEDIA TO FLOW THROUGH.

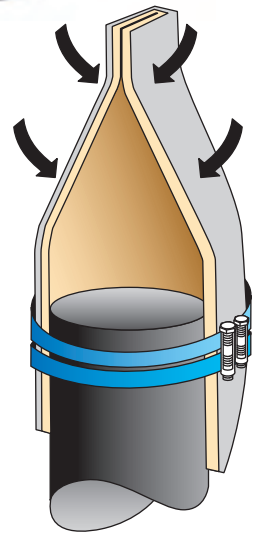

THE FLEX-VALVE® STYLE 4100 CHECK VALVE ILLUSTRATED CLOSED WITH REVERSE PRESSURE SEALS THE VALVE CLOSED, EVEN ON SOLIDS, TO PREVENT BACKFLOW INTO THE PROCESS LINE.

#### Typical Applications:

**Storm Water Outfall/Overflow:** The Flex-Valve® Style 4100 & 4200 Duck-Bill check valves provide quiet, maintenance-free operation with an added benefit of low opening pressure. The low opening pressure eliminates standing water – a major health concern.

**Submerged Outfall Diffuser:** The Flex-Valve® Style 4100 & 4200 Duck-Bill check valves will eliminate marine fouling and backflow intrusion with an added benefit of higher jet velocities. The high jet velocity is also found at low flow rates, providing a more uniform port discharge distribution.

The versatile construction and our creative design team can adapt the Flex-Valve® Style 4100 & 4200 Duck-Bill check valves to additional applications including, but not limited to: water mixing systems, overflow vents, anti-siphon devices, coarse bubble diffusers, floor drains, sparging devices, or when needed, a device to increase back pressure in a pipe line.

#### Elastomers Available:

Pure Gum Rubber, Neoprene, EPDM, Buna-N (Nitrile), Hypalon®, Chlorobutyl, and Viton®.

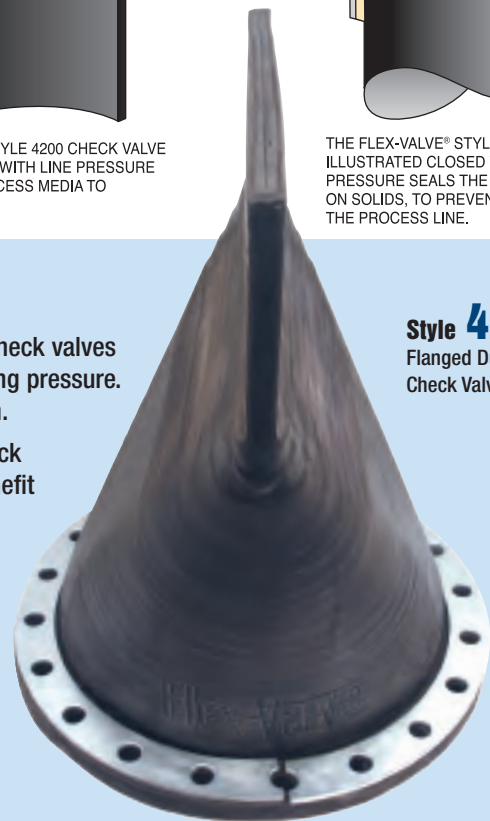

**Style 4200**  
Flanged Duck-Bill  
Check Valve



# Flex-Valve®

## Duck-Bill Check Valves

### Style 4100

Slip-on Duck-Bill  
Check Valve

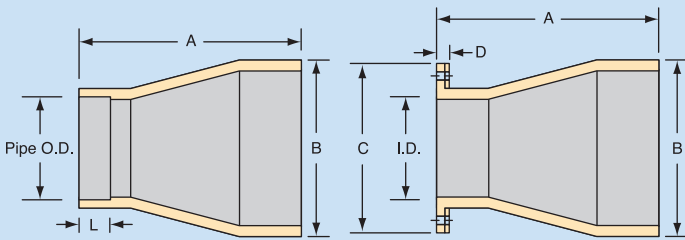

Style 4100 Slip-on Duck Bill Check Valve

Style 4200 Flanged Duck Bill Check Valve



### DIMENSIONS

Pipe Size	STYLE 4100		STYLE 4200			Height B
	Mating Pipe O.D.	Cuff Slip-on Length L	Flange O.D. C	Flange Thickness D	Length A	
1/2	5/8	1/2	3-1/2	7/8	2-1/2	1-1/2
3/4	1	1	3-7/8	7/8	3	1-1/2
1	1-5/16	1	4- 1/4	7/8	3	1-1/2
1-1/4	1-13/16	1	4-5/8	7/8	5-3/4	2-3/4
1-1/2	1-15/16	1	5	7/8	6	3
2	2-3/8	1-1/2	6	7/8	6	4
2-1/2	2-7/8	2	7	7/8	8	5
3	3-1/2	3	7-1/2	1-1/8	9	5-1/2
4	4-1/2	3	9	1-1/8	12	7
5	5-9/16	3	10	1-1/8	15-1/2	9
6	6-5/8	4	11	1-3/8	16	10-1/2
8	8-5/8	4	13-1/2	1-3/8	16-1/2	13
10	10-3/4	4	16	1-3/8	21-1/2	17
12	12-3/4	6	19	1-3/8	26	20-1/2
14	14	6	21	1-3/8	26	22
16	16	6	23-1/2	1-3/8	26	27
18	18	6	25	1-3/8	30	29
20	20	8	27-1/2	1-7/8	33	33
22	22	8	29-1/2	1-7/8	38	33
24	24	8	32	1-7/8	40	37
30	30	10	38-3/4	1-7/8	42	50
32	32	10	41-3/4	1-7/8	48	53
36	36	10	46	1-7/8	50	61
42	42	12	50 3/4	2-3/8	54	71
48	48	12	53	2-3/8	60	78

Notes: 1) Style 4100 sizes are based on Schedule 40 pipe. Other I.D. dimensions are available. 2) Dimensions are subject to change due to customized construction. Steel, Concrete, and Ductile Iron Pipe O.D.s vary. 3) Flex-Valve®, Duck-Bill Check Valve's dimensions are based on actual pipe and therefore it is important to verify pipe O.D. for proper sizing. 4) For full product specifications and installation instructions, see SPEC4100-1, SPEC4200-1 and ININ4100-1, ININ4200-1, respectively. 5) All dimensions expressed in inches. Contact General Rubber for sizes not shown and higher pressure ratings. 6) Customer to provide head pressure and maximum back pressure when ordering.



# Flex-Valve®

## Duck-Bill In-Line Check Valves

### Series 4300

#### Features:

- Reliable and cost-effective alternative to conventional in-line check valves
- Eliminates backflow and seals around entrapped solids
- Rugged all-elastomer construction in a full variety of materials
- Maintenance-free operation with no mechanical components that can corrode or seize
- Lower head loss than conventional check valves
- Will open with as little as 1" W.C.
- Quiet operation (non-slamming)
- Non-plugging
- Excellent corrosion and abrasion resistance
- Versatile construction for a wide range of applications
- Style 4300 and 4350 are manufactured to fit inside standard pipe. No valve body is required, making them cost effective and ideal for difficult applications including: tank outlets, floor drains, sewer interceptors, overflow systems, retention basins and manhole outlets. The smaller bill width will increase the pressure drop and will maintain a maximum of 75% of the full port area. Style 4300 is bolted in place between two flanges. Style 4350 is secured in place with an expandable clamp.
- Style 4320 is manufactured for full flow with a minimum pressure drop. The enclosed body is provided with flush and clean out ports for ease of maintenance.

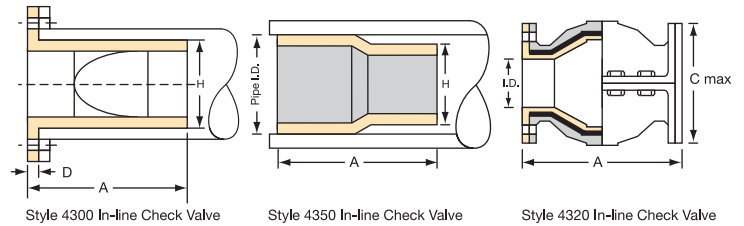

THE FLEXIBLE-VALVE IN-LINE CHECK VALVES OPEN WITH LINE PRESSURE TO ALLOW THE PROCESS MEDIA TO FLOW THROUGH

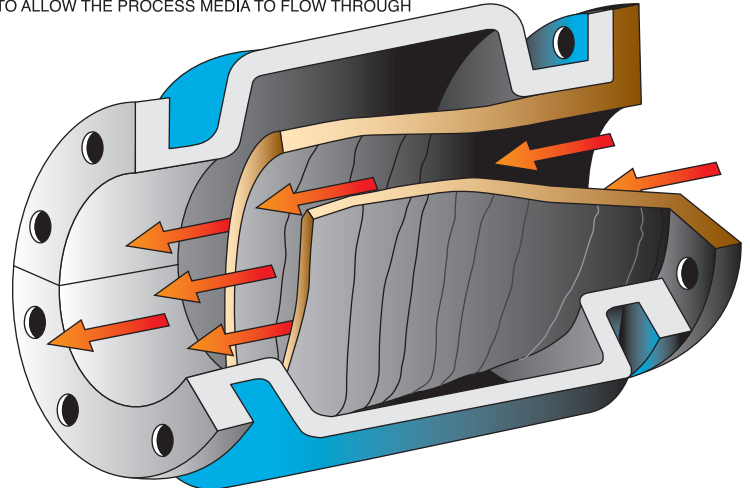

WITH REVERSE PRESSURE THE VALVE CLOSES EVEN ON SOLIDS TO PREVENT BACKFLOW

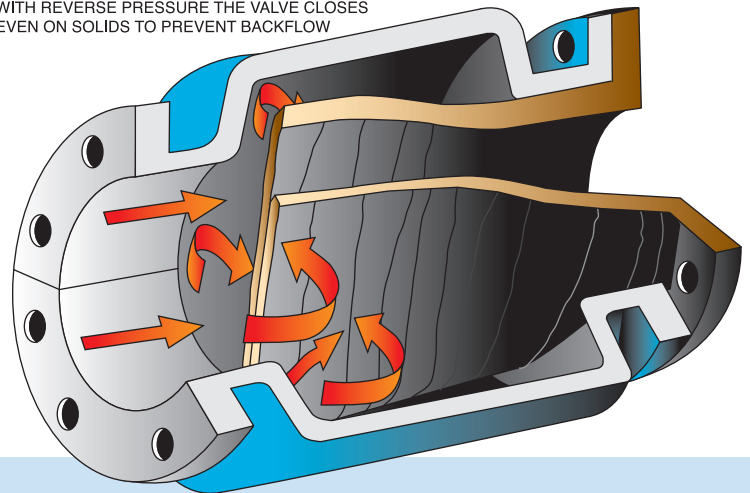

#### DIMENSIONS

Pipe Size	STYLE 4300 & 4350		STYLE 4320			Height C
	Length A	Flange O.D. C	Flange Thickness D	Height H	Length A	
2	6	6	1/2	1-7/8	8-1/2	6-1/2
3	6	7 1/2	1/2	2-7/8	11-1/4	8
4	8	9	3/4	3-7/8	11-1/2	10-3/4
6	12	11	3/4	5-7/8	14	14
8	14	13-1/2	3/4	7-7/8	19-1/2	17-1/4
10	16	16	3/4	9-7/8	24-1/2	22-3/4
12	20	19	1	11-7/8	27-1/2	24-3/4
14	24	21	1	12-3/4	31	27-3/4
16	26	23-1/2	1	14-3/4	34	31-1/4
18	28	25	1	16-3/4	38-1/2	35
20	32	27-1/2	1	18-3/4	40	42-3/4
24	34	32	1	22-3/4	51	45-1/2

Notes: 1) For full product specifications and installation instructions, see SPEC4300-1, SPEC4350-1, SPEC4320-1 and ININ4300-1, ININ4350-1, ININ4320-1, respectively. 2) All dimensions expressed in inches. Contact General Rubber for sizes not shown and higher pressure ratings. 3) Customer to provide head pressure and maximum back pressure when ordering.



# Flex-Valve®

## Folded-Bill Check Valve

### Style 4500

#### Features:

- Minimum clearance required in all directions
- Bill width measures a little more than the pipe O.D. making both the top and bottom "FLAT"
- Ideal for manhole and vault installations
- Innovative Folded-Bill, unfolds to full port area with a minimum pressure drop
- Eliminates backflow and seals around entrapped solid
- Rugged all elastomer construction in a variety of materials
- Maintenance-free operation with no mechanical components that can corrode or seize
- Will open with as little as 1" W.C.
- Quiet operation (non-slamming)
- Non-plugging
- Excellent corrosion and abrasion resistance
- Available in slip-on or flanged design

#### Typical Applications:

The innovative and compact Flex-Valve style 4500 Folded-Bill check valve functions and operates under the same principle as our standard duck bill check valve without the large bill width. The integral reinforcement in the bill area is folded over itself providing a minimized bill width that measures little more than the pipe O.D. These same folds open easily for full flow with a minimum pressure drop. The smaller bill width will seal better and resist gapping. The compact design makes it ideal for retrofitting of existing interceptors, manholes and vaults. The improved bottom clearance is obtained without sacrificing top clearance. It has been found that space is always tight in all directions, and this is why the Flex-Valve style 4500 is ideal for both retrofitting and new construction applications.

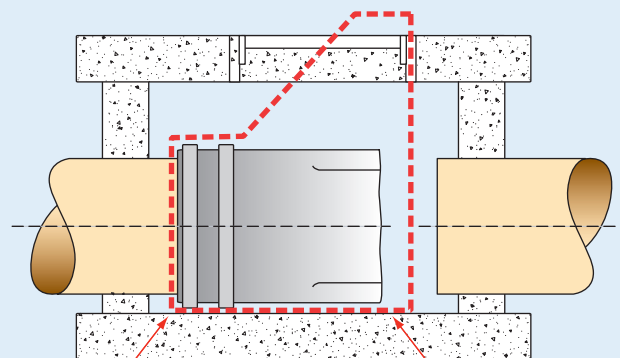
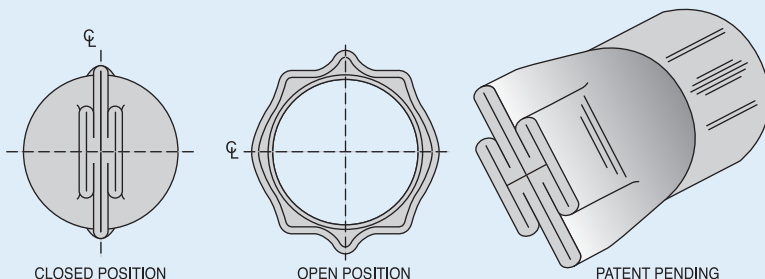

ALTERNATIVE DESIGN, DASHED IN RED, ILLUSTRATES THAT IMPROVED BOTTOM CLEARANCE IS OBTAINED WHEN TOP CLEARANCE IS SACRIFICED.

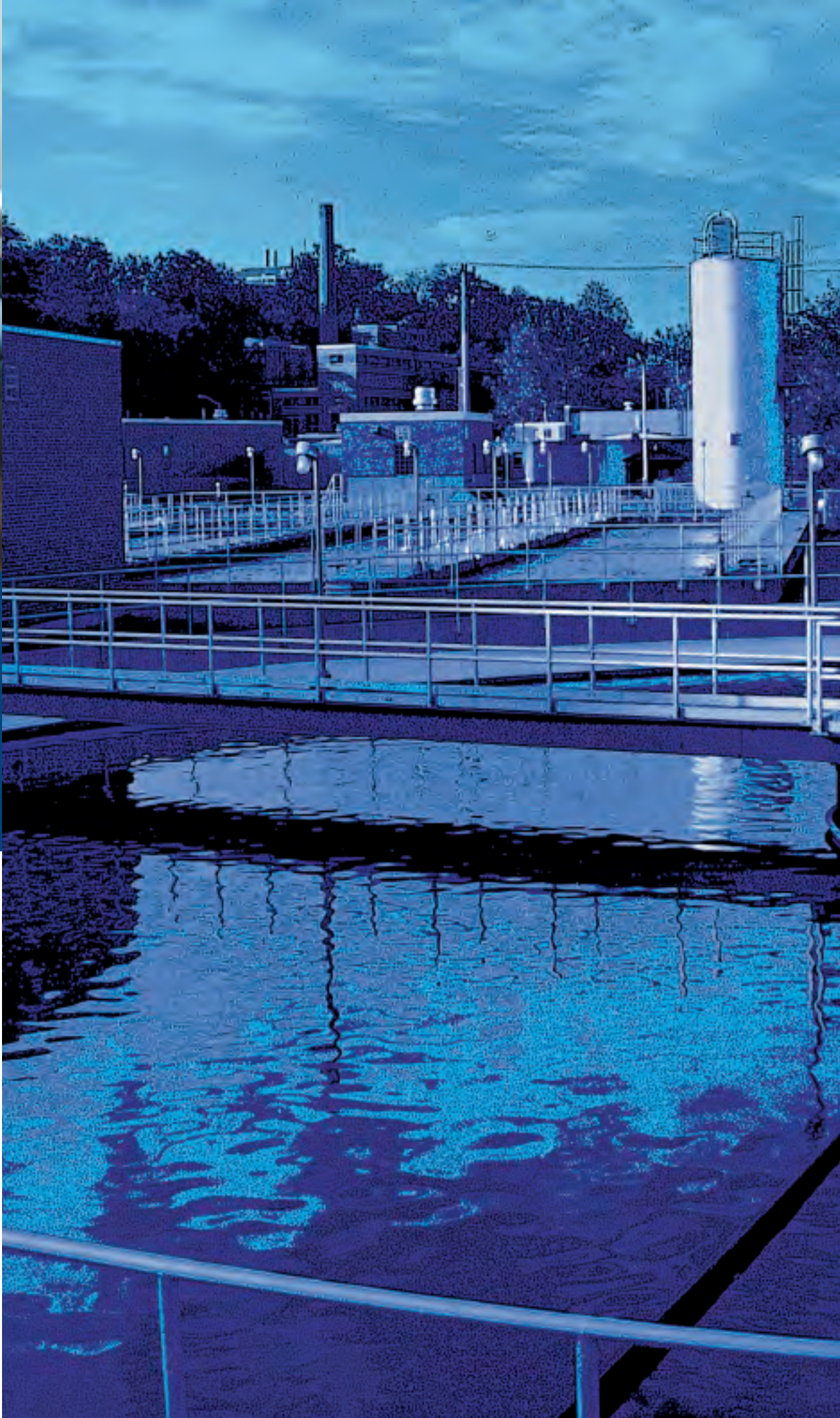

*The information presented in this catalog is provided in good faith. General Rubber Corp. reserves the right to modify or improve its design specifications without notice and does not imply any guarantee or warranty for any of its products from reliance upon the information contained herein. For specific application recommendations, consult General Rubber Corp. Failure to properly select products could result in property damage and/or serious personal injury. All orders are subject to final acceptance by General Rubber Corp.*



**General Rubber Corporation**  
850 Washington Avenue  
Carlstadt, New Jersey 07072

Phone: **201-935-1900** Toll Free: **800-233-6294**  
Fax: **201-935-1915**

[www.general-rubber.com](http://www.general-rubber.com)

[sales@general-rubber.com](mailto:sales@general-rubber.com)

© 2008, General Rubber Corporation.

Printed in U.S.A.



GR-301

GR-219/5M/01-08