

Shown with
Control Unit
GR/B

Style 1101 Rubber Expansion Joint

5" ID x 6" F/F (DN125mm x 152mm) - 150-lb Drilling | 1101-0005-3.16

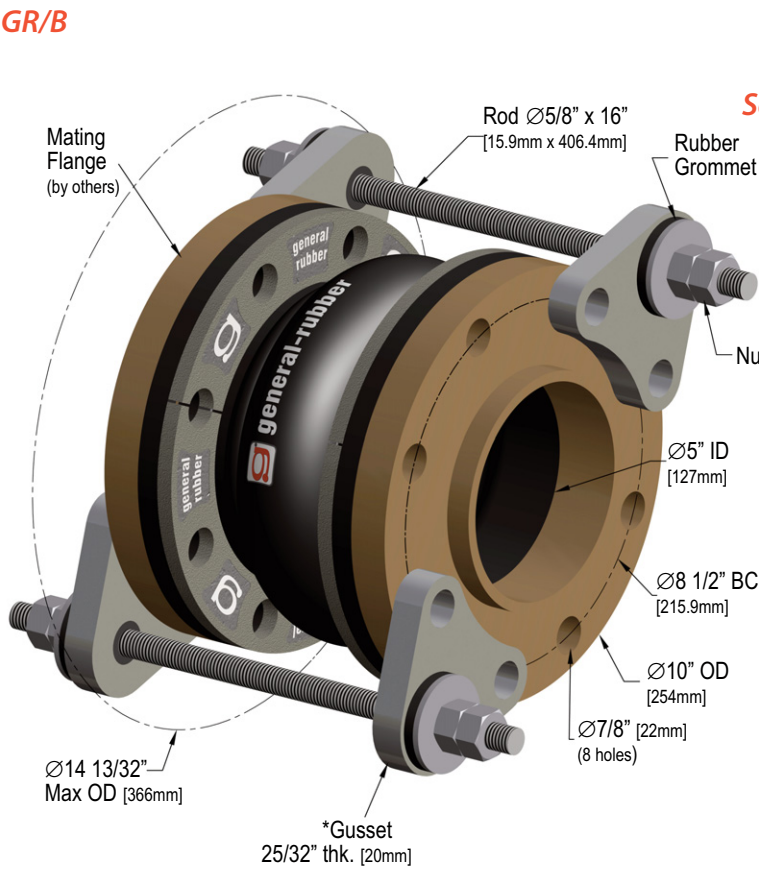

Section Detail

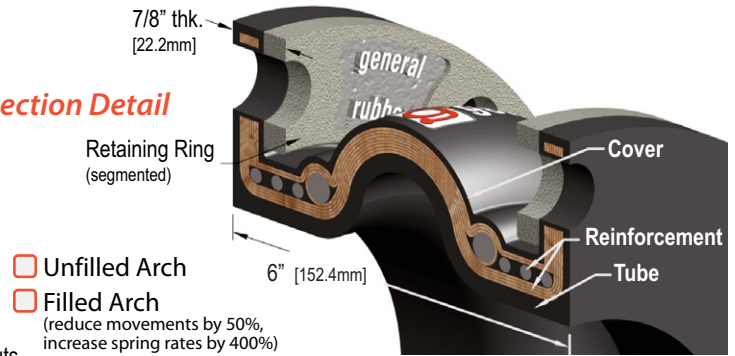

	Pure Gum	Neoprene	Butyl	Nitrile (Buna-N)	EPDM	Viton® (FKM)
<input type="checkbox"/> Tube	<input type="checkbox"/>	<input type="checkbox"/>	<input type="checkbox"/>	<input type="checkbox"/>	<input type="checkbox"/>	<input type="checkbox"/>
<input type="checkbox"/> Cover	<input type="checkbox"/>	<input type="checkbox"/>	<input type="checkbox"/>	<input type="checkbox"/>	<input type="checkbox"/>	<input type="checkbox"/>
Tire Cord:	° F [° C]	° F [° C]	° F [° C]	° F [° C]	° F [° C]	° F [° C]
<input type="checkbox"/> Polyester	180 [82]	225 [107]	250 [121]	210 [99]	250 [121]	250 [121]
<input type="checkbox"/> Kevlar®	180 [82]	225 [107]	300 [149]	210 [99]	350 [177]	400 [204]

Maximum Temperature rating based on lowest temperature material selected. EPDM or Butyl w/Polyester Tire Cord rated 300°F (149°C) for Air Service up to 25 psig (1.7 barg)

Bill of Materials

ITEM	MATERIAL	FINISH
Retaining Ring	<input type="checkbox"/> Carbon Steel	Hot Dipped Galvanized
	<input type="checkbox"/> Stainless Steel	Plain
Gusset	<input type="checkbox"/> Carbon Steel	Hot Dipped Galvanized
	<input type="checkbox"/> Stainless Steel	Plain
Rods	<input type="checkbox"/> ASTM A193 B7 Alloy Steel	Hot Dipped Galvanized
	<input type="checkbox"/> ASTM A193 B8M 316 SS	Plain
Nuts	<input type="checkbox"/> ASTM A194 2H Steel	Hot Dipped Galvanized
	<input type="checkbox"/> ASTM A194 8M 316 SS	Plain
Spherical Washers	<input type="checkbox"/> Stainless Steel	Plain
Metal Reinforcement	High Tensile Steel	Rubber Embedded
Textile Reinforcement	Tire Cord	RFL Coating

MOVEMENT (non-concrtk)					SPRING RATE					PRESSURE		WEIGHT	
Comp. in [mm]	Ext. in [mm]	Lateral in [mm]	Angular deg.	Torsional deg.	Comp. lb/in [N/mm]	Ext. lb/in [N/mm]	Lateral lb/in [N/mm]	Angular ft-lb/deg [N-m/deg]	Torsional ft-lb/deg [N-m/deg]	Pressure psig [barg]	Vacuum in-Hg [barg]	RBJ with Rings lbs [kg]	Control Unit lbs [kg]
1 3/4 [44]	7/8 [22]	1 [25]	18	3.4	670 [117]	880 [154]	710 [124]	3.6 [4.9]	6.2 [8.4]	225 [15.5]	30 [-1]	17 [9]	16 [7]

Optional Control Units

No Control Units

Outer Washer / Grommet Inner Bare (GR/B) (shown above)

Inner Nuts (GR/W)

Spherical Washer (GR-SW/B)

Spherical Washer (GR-SW/SW)

Integral Ring (INT-W/B)

Integral Ring (INT-W/W)

Integral Ring, Spherical Washer (INT-SW/SW)

*No. of Rods: 2 Rods / 225 psig

*Gusset thickness and pressure listed above are for carbon steel gussets and ASTM A193 B7 rods. Contact General Rubber for stainless steel pressures and thicknesses. Contact General Rubber Corporation for full product specifications, Warnings and installation instructions.